



CARIBBEAN  
EXAMINATIONS  
COUNCIL

Caribbean Advanced  
Proficiency Examination®

# SYLLABUS

# BIOLOGY

CXC A10/U2/17

Effective for examinations from May–June 2019



Correspondence related to the syllabus should be addressed to:

The Pro-Registrar  
Caribbean Examinations Council  
Caenwood Centre  
37 Arnold Road, Kingston 5, Jamaica

Telephone Number: + 1 (876) 630-5200  
Facsimile Number: + 1 (876) 967-4972  
E-mail Address: [cxcwzo@cxc.org](mailto:cxcwzo@cxc.org)  
Website: [www.cxc.org](http://www.cxc.org)

Copyright ©2017 by Caribbean Examinations Council  
Prince Road, Pine Plantation Road, St Michael BB11091



# Contents

INTRODUCTION.....	i
RATIONALE .....	2
AIMS.....	3
SKILLS AND ABILITIES TO BE ASSESSED .....	3
PREREQUISITES OF THE SYLLABUS .....	6
STRUCTURE OF THE SYLLABUS.....	7
SUGGESTIONS FOR TEACHING THE SYLLABUS.....	7
THE PRACTICAL APPROACH.....	8
UNIT 1: BIOMOLECULES, REPRODUCTION AND DEVELOPMENT .....	12
MODULE 1: CELL AND MOLECULAR BIOLOGY .....	12
MODULE 2: GENETICS, VARIATION AND NATURAL SELECTION.....	18
MODULE 3: REPRODUCTIVE BIOLOGY .....	25
UNIT 2: BIOENERGETICS, BIOSYSTEMS AND APPLICATIONS.....	30
MODULE 1: BIOENERGETICS AND CONSERVATION .....	30
MODULE 2: BIOSYSTEMS MAINTENANCE.....	37
MODULE 3: APPLICATIONS OF BIOLOGY .....	43
OUTLINE OF ASSESSMENT.....	50
REGULATIONS FOR PRIVATE CANDIDATES .....	57
REGULATIONS FOR RESIT CANDIDATES .....	57
ASSESSMENT GRID .....	58
RESOURCES .....	59
APPENDIX I: GLOSSARY .....	61



This document CXC A10/U2/17 replaces CXC A10/U2/07 issued in 2007. Please note that the syllabus has been revised and amendments are indicated by italics.

First issued 1999  
Revised 2001  
Revised 2007  
Revised 2017

Please check the website, [www.cxc.org](http://www.cxc.org) for updates on **CXC**<sup>®</sup>'s syllabuses.



CAPE<sup>®</sup>

CXC A10/U2/17

# Introduction

The Caribbean Advanced Proficiency Examination® (**CAPE**®) is designed to provide certification of the academic, vocational and technical achievement of students in the Caribbean who, having completed a minimum of five years of secondary education, wish to further their studies. The examinations address the skills and knowledge acquired by students under a flexible and articulated system where subjects are organised in 1-Unit or 2-Unit courses with each Unit containing three Modules. Subjects examined under **CAPE**® may be studied concurrently or singly.

The Caribbean Examinations Council offers three types of certification at the **CAPE**® level. The first is the award of a certificate showing each **CAPE**® Unit completed. The second is the **CAPE**® Diploma, awarded to candidates who have satisfactorily completed at least six Units, including Caribbean Studies. The third is the **CXC**® Associate Degree, awarded for the satisfactory completion of a prescribed cluster of eight **CAPE**® Units including Caribbean Studies, Communication Studies and Integrated Mathematics. Integrated Mathematics is not a requirement for the **CXC**® Associate Degree in Mathematics. The complete list of Associate Degrees may be found in the **CXC**® Associate Degree Handbook.

For the **CAPE**® Diploma and the **CXC**® Associate Degree, candidates must complete the cluster of required Units within a maximum period of five years. To be eligible for a **CXC**® Associate Degree, the educational institution presenting the candidates for the award, must select the Associate Degree of choice at the time of registration at the sitting (year) the candidates are expected to qualify for the award. Candidates will not be awarded an Associate Degree for which they were not registered.



# Biology Syllabus

## ◆ RATIONALE

Science plays a major role in the evolution of knowledge. It empowers us to use creative and independent approaches to problem-solving. It arouses our natural curiosity and enables us to meet diverse and ever expanding challenges. It enhances our ability to inquire, seek answers, research, and interpret data. These skills *use the scientific method which* lead to the construction of theories and laws that help us to explain natural phenomena and exercise control over our environment. Science is, thus, an integral component of a balanced education.

The life sciences involve the study of living organisms and their life processes. Biology is at the core of the life sciences and allows for the examination, investigation and recording of the diverse forms of life. The study of Biology leads to an understanding and appreciation of the concept of life at all levels and hence, to a greater respect and reverence for life. The interconnected web of life and the unique role of the human species are integral to the dynamic nature of the biosphere. Students of Biology should recognise the enormous responsibility which must be undertaken to ensure the continuity of life in all its forms. It is incumbent that student use this knowledge to protect, sustain, manage, conserve and improve the variety of life in the ecosphere. Additionally, the study of Biology prepares students for careers in biological, agricultural, environmental, medical, paramedical and applied sciences.

The CAPE® Biology Syllabus is redesigned with a greater emphasis on the application of scientific concepts and principles. It recognises the need for an understanding of some of the basic principles of Chemistry, Physics and Mathematics, and, therefore seeks to strengthen the inter-relationship with these subjects. It also recognises the inter-relatedness among the topics in Biology, and social and environmental issues. Such an approach is adopted to develop those long-term transferable skills of ethical conduct, teamwork, problem-solving, critical thinking, innovation, and communication. It encourages the use of various student-centred teaching-learning strategies to inculcate the knowledge and competencies that will prove useful in everyday life, while at the same time catering to multiple intelligences and different learning styles and needs. It will provide a sound foundation to pursue the study of Life Sciences and related professions at the post-secondary level.

*The most important natural resource in the Caribbean is its people. If the Caribbean is to play an important role in the new global village and survive economically, a sustained development of the scientific and technological resources of its people is essential.* This syllabus will contribute to the development of the Ideal Caribbean Person as articulated by the CARICOM Heads of Government in the following areas: respect for human life and awareness of the importance of living in harmony with the environment; demonstration of multiple literacies; independent and critical thinking and the innovative application of science and technology to problem-solving. In keeping with the UNESCO Pillars of Learning, on completion of the study of this course, students will learn to do, learn to be and learn to transform themselves and society.



## ◆ AIMS

The syllabus aims to:

1. enable students to acquire a body of knowledge and develop an understanding of biological concepts and principles;
2. promote an understanding of how new information can contribute to the reformulation or rejection of earlier models and concepts;
3. recognise the scope of Biology at all levels from the molecular level to that of body systems and entire ecosystems;
4. facilitate the development of the ability to communicate scientific information in a logical and structured manner;
5. develop an understanding of the scientific method and the ability to apply it to solving problems, both in academic and non-academic settings;
6. *assist in the development of critical thinking, analytical, and practical skills;*
7. encourage students to appreciate the impact of biological knowledge on society and its relevance to ethical, economic, environmental and technological issues;
8. develop the ability to apply biological knowledge and skills to relevant Caribbean situations and issues;
9. develop the ability to work independently and collaboratively with others;
10. promote an appreciation of the significance and limitations of science in relation to social and economic development; and,
11. promote the integration of Information Communication and Technology (ICT) tools and skills.

## ◆ SKILLS AND ABILITIES TO BE ASSESSED

The skills students are expected to develop on completion of this syllabus, have been grouped under three main headings:

1. Knowledge and Comprehension;
2. Use of Knowledge; and,
3. Experimental Skills.

### 1. Knowledge and Comprehension (KC)

- (a) Knowledge – the ability to identify, remember and grasp the meaning of basic facts, concepts and principles.

(b) Comprehension

The ability to:

- (i) select appropriate ideas, match, compare and cite examples of facts, concepts and principles in familiar situations; and,
- (ii) explain familiar phenomena in terms of theories, models, laws and principles.

**2. Use of Knowledge (UK)**

(a) Application

The ability to:

- (i) use facts, concepts, principles and procedures in unfamiliar situations;
- (ii) transform data accurately and appropriately;
- (iii) use common characteristics as a basis for classification; and,
- (iv) use formulae accurately for computations.

(b) Analysis and Interpretation

The ability to:

- (i) identify and recognise the component parts of a whole and interpret the relationships between those parts;
- (ii) identify causal factors and show how they interact with each other;
- (iii) infer, predict and draw conclusions; and,
- (iv) make necessary and accurate calculations and recognise the limitations and assumptions of data.

(c) Synthesis

The ability to:

- (i) combine component parts to form a new meaningful whole; and,
- (ii) make predictions and solve problems.

(d) Evaluation – the ability to make reasoned judgements and recommendations based on the value of ideas and information and their implications.



### 3. Experimental Skills (XS)

#### (a) Observation, Recording and Reporting

The ability to:

- (i) make accurate observations and minimise experimental errors;
- (ii) recognise, identify and interpret biological materials both microscopically and macroscopically;
- (iii) record observations, measurements, methods and techniques with due regard for precision, accuracy and units;
- (iv) record and report unexpected results;
- (v) select and use appropriate modes of recording data or observations, for example, graphs, tables, diagrams and drawings;
- (vi) present data in an appropriate manner, using the accepted convention of recording errors and uncertainties;
- (vii) organise and present information, ideas, descriptions and arguments clearly and logically in a complete report, using spelling, punctuation and grammar with an acceptable degree of accuracy; and,
- (viii) report accurately and concisely using scientific terminology and conventions as necessary.

#### (b) Manipulation and Measurement

The ability to:

- (i) follow a detailed set or sequence of instructions;
- (ii) make measurements with due regard for precision and accuracy;
- (iii) handle chemicals and living organisms with care;
- (iv) cut, stain and mount sections and make temporary mounts;
- (v) set up light microscope for optimum use both under low power and high power;
- (vi) use the stage micrometer and eyepiece graticule for accurate measuring; and,
- (vii) assemble and use simple apparatus and measuring instruments.

(c) Drawing

The ability to:

- (i) make clear, accurate line representations of specimens, with no shading or unnecessary details;
- (ii) produce *illustrations* with clean continuous lines of even thickness;
- (iii) label *illustrations* accurately and use label lines which do not cross each other or carry arrowheads or dots;
- (iv) annotate *illustrations* appropriately and accurately;
- (v) make illustrations which are large enough to display specific details; and,
- (vi) calculate the magnification of the *illustrations*.

*Note: A drawing is used to illustrate a three-dimensional representation of a specimen whereas a diagram illustrates the surface view of a section cut through the specimen.*

(d) Planning and Designing

The ability to:

- (i) identify problems, make predictions, develop hypotheses and devise means of carrying out investigations to test the hypotheses;
- (ii) plan and execute experimental procedures and operations in an appropriate sequence;
- (iii) use experimental controls where appropriate;
- (iv) modify an original plan or sequence of operations as a result of difficulties encountered in carrying out experiments or obtaining unexpected results;
- (v) take into account possible sources of errors and danger in the design of an experiment; and,
- (vi) select and use appropriate equipment and techniques.

Planning and Designing skills may be assessed through the use of fieldwork.

## ◆ PREREQUISITES OF THE SYLLABUS

Any person with a good grasp of the Caribbean Secondary Education Certificate (CSEC®) Biology and Chemistry syllabuses, or the equivalent, should be able to pursue the course of study defined by this syllabus. However, successful participation in the course of study will also depend on the possession of good verbal and written communication skills.



## ◆ STRUCTURE OF THE SYLLABUS

The subject is organised in two Units. A Unit comprises three Modules each requiring 50 hours. The total time for each Unit, is therefore, expected to be 150 hours. Each Unit can independently offer students a comprehensive programme of study with appropriate balance between depth and coverage to provide a basis for further study in this field.

### Unit 1: Biomolecules, Reproduction and Development

Module 1	-	Cell and Molecular Biology
Module 2	-	Genetics, Variation and Natural Selection
Module 3	-	Reproductive Biology

### Unit 2: Bioenergetics, Biosystems and Applications

Module 1	-	Bioenergetics and Conservation
Module 2	-	Biosystems Maintenance
Module 3	-	Applications of Biology

It is recommended that of the approximately 50 hours suggested for each Module, a minimum of 20 hours be spent on laboratory-related activities, such as conducting experiments, making field trips and viewing audio-visual materials.

## ◆ SUGGESTIONS FOR TEACHING THE SYLLABUS

The organisation of each module in the syllabus is designed to facilitate inquiry-based learning and to ensure that connections among biological concepts are established. Teachers should ensure that their lessons stimulate the use of all the senses in learning as this will help students view science as a dynamic and exciting investigative process. Although the units are presented in a sequential manner, teachers are encouraged to utilise a thematic approach in the implementation of the syllabus.

The general and specific objectives indicate the scope of the content and include suggested practical activities that should be covered. Explanatory notes are provided to the right of some specific objectives. These notes provide further guidance to teachers as to the level of detail required. Suggested *Practical Activities* indicate those areas of the syllabus that are suitable for practical work. However, practical work should not necessarily be limited to these suggested activities, since unfamiliar situations may be presented as stimulus material in examination questions.

This syllabus caters to varying teaching and learning styles, with specific attention being drawn to the interrelatedness of concepts. Whenever possible, a practical approach should be employed, with special attention given to the identification of variables and to the use of controls in biological investigations. Students should be encouraged to use information gathering tools and social networking platforms to aid investigation and teamwork. The need for repeated investigation and observation to arrive at meaningful conclusions should be emphasised.

Greater emphasis should be placed on the application of scientific concepts and principles, and less on the factual materials, which encourage memorisation and short-term recall. Opportunities should



be provided for relating biological studies to the environment and to use an ecological approach whenever pertinent. Biological principles should be illustrated by specific local and regional examples. The use of scientific names to identify organisms is preferable.

The relationship between structure and function, cause and effect, stability and change is to be continually highlighted. Where appropriate, this relationship should be illustrated by the use of annotated diagrams/drawings.

The role of the teacher is to facilitate students' learning of accurate and unbiased information that will contribute to a more scientifically literate society, capable of making educated and ethical decisions regarding the world in which we live.

## ◆ THE PRACTICAL APPROACH

The syllabus is designed to foster the use of inquiry-based learning through the application of the practical approach. Students will be guided to answer scientific questions by a process of making observations, asking questions, doing experiments and analysing and interpreting data. The **CAPE®** Biology Syllabus focuses on the following skills.

### 1. Planning and Designing (PD)

- (a) Ask questions: how, what, which, why or where. (Students must be guided by their teachers to ask scientific questions).

Observation: Growth of plants are affected by their environment.

Example: Will plants that are grown using organic fertilizers grow taller than those that are grown using inorganic fertilizers?

- (b) Construct a hypothesis: the hypothesis must be clear, concise and testable.

Example: Plants grown using organic fertilizer will grow taller than those grown using inorganic fertilizer.

- (c) Design an experiment to test the hypothesis. Experimental reports must include the following:

- (i) problem statement;
- (ii) an appropriate aim related to the hypothesis;
- (iii) list of materials and apparatus to be used;
- (iv) observations to be made or measurements to be taken;
- (v) precautions to be taken;
- (vi) method of controlling variables;
- (vii) clear and concise step by step procedure;

- (viii) state expected results (*format of table expected*);
- (ix) use of results; and,
- (x) possible limitations.

2. Measurement and Manipulation (MM)

- (a) Student's ability to handle scientific equipment competently.

The list of equipment is:

- (i) Bunsen burner;
  - (ii) Tripod stand with wire gauze;
  - (iii) binocular and monocular light microscope;
  - (iv) measuring cylinders (25-100cm<sup>3</sup>);
  - (v) beaker (50-500cm<sup>3</sup>);
  - (vi) thermometer;
  - (vii) ruler;
  - (viii) stop watch/clock;
  - (ix) balance;
  - (x) boiling tube;
  - (xi) test tubes and test tube holders;
  - (xii) hand lens; and,
  - (xiii) syringe.
- (b) Student's ability to take accurate measurements.
- (c) Student's ability to use appropriate units.

3. Observation, Reporting and Recording (ORR)

- (a) Recording

Student's ability to record observations and to collect, organise and present data. Observations and data may be recorded in the following format.

- (i) Prose  
Written description of observations in the correct tense.
  - (ii) Table (Neatly enclosed)  
Numerical: physical quantities in heading, units stated in heading, symbols, decimal points.  
Non-numerical: headings correct, details present.
  - (iii) Graph  
Axes labelled, correct scales, correct plotting, smooth curves/best fit lines, key to explain symbols if more than one dependent variable is being plotted.
- (b) Reporting

Student's ability to prepare a comprehensive written report on their assignments using the following format:

- (i) **Date** (date of experiment).
- (ii) **Aim/Purpose** (what is the reason for doing the experiment).
- (iii) **Apparatus and Materials** (all equipment, chemicals and materials used in the experiment must be listed).
- (iv) **Method/Experimental Procedure** (logically sequenced, step-by-step procedure written in the past tense, passive voice).
- (v) **Results and Observations** (see (a) above: Recording).
- (vi) **Discussion**
- (vii) **Conclusion** (*should be related to the Aim*).

#### 4. Analysis and Interpretation

Student's ability to:

- (a) identify patterns and trends, cause and effect, stability and change;
- (b) make accurate calculations;
- (c) identify limitations and sources of error;
- (d) make a conclusion to either support or refute the hypothesis;
- (e) compare actual results with expected results based on background/theoretical knowledge if they are different;
- (f) suggest alternative methods or modification to existing methods; and,
- (g) analyse and interpret results and observations and making conclusions.

5. Drawing (Dr)

The following guidelines should be used for drawing:

- (a) The *illustrations* should be placed in a position on the page which will allow for neat and clear labelling.
- (b) If the *illustration* is included in the written material, it should be placed just before this material and should be referred to in your answer.
- (c) *Illustrations* should be done in pencil. The use of coloured pencils is not acceptable.
- (d) The *illustration* should be large enough so that all structures can be clearly drawn.
- (e) The *illustration* should be correctly proportioned and parts should be accurately positioned.
- (f) In order to get a smooth, unbroken line when drawing, lift the pencil from the paper as infrequently as possible until the line is completely drawn. This method will help to eliminate haphazard and sketchy lines.
- (g) When a large number of small structures are present in a specimen, draw only a few of them carefully, showing structural details.
- (h) Write labels in pencil.
- (i) Labels should be annotated (that is, accompanied by brief explanatory notes).
- (j) Label lines should never cross each other and should be horizontal where possible.
- (k) In *illustrations* where only a few structures are being labelled, all labels should be written on the right of the drawing.
- (l) Biological *illustrations* must have a full title and magnification. This is usually written below the drawn item and underlined. The title tells the name of the structure or organism and the view from which the *illustration* was made.

*Note: A diagram should clearly indicate the following:*

- *tissues present;*
- *the position of the tissues in the organ relative to each other; and,*
- *the proportion of the tissues relative to each other in the section.*

◆ **UNIT 1: BIOMOLECULES, REPRODUCTION AND DEVELOPMENT**  
**MODULE 1: CELL AND MOLECULAR BIOLOGY**

**GENERAL OBJECTIVES**

On completion of this Module, students should:

1. understand the chemical structure of water, carbohydrates, lipids and proteins and their roles in living organisms;
2. understand that cells are the basic units of living organisms, grouped into tissues and organs;
3. relate cell organelles to their functions;
4. understand the Fluid Mosaic Membrane model and the movement of substances into and out of cells; and,
5. understand the mode of action of enzymes.

**SPECIFIC OBJECTIVES**

**EXPLANATORY NOTES**

**SUGGESTED PRACTICAL ACTIVITIES**

**1. Aspects of Biochemistry**

Students should be able to:

- |      |   |   |   |
|------|---|---|---|
| 1.1. | discuss how the structure and properties of water relate to the role that water plays as a medium of life;                | Water as a most suitable solvent in relation to its essential roles in transport: cellular and systemic levels. | <i>Compare solubility of substances in liquids of different polarities.</i> |
| 1.2. | <i>discuss that macromolecules are polymers made up of their individual monomers and formation and breakage of bonds;</i> |   |   |
| 1.3. | explain the relationship between the structure and function of glucose;   | Exact molecular ring structure in full.<br><i>Distinguish between the structures of alpha and beta glucose.</i> |   |
| 1.4. | explain the relationship between the structure and function of sucrose;   | Exact molecular ring structure in full.   |   |





## UNIT 1

### MODULE 1: CELL AND MOLECULAR BIOLOGY (cont'd)

#### SPECIFIC OBJECTIVES

#### EXPLANATORY NOTES

#### SUGGESTED PRACTICAL ACTIVITIES

#### Aspects of Biochemistry (cont'd)

Students should be able to:

- |       |   |  |   |
|-------|---|--|---|
| 1.5.  | discuss how the molecular structure of starch, glycogen and cellulose relate to their functions in living organisms;                      | Molecular structure: types of bonds; chain and ring structure where appropriate; 3D nature; hydrolysis and condensation reactions; relate structure to properties. |   |
| 1.6.  | describe the molecular structure of a triglyceride and its role as a source of energy;  | Without going into detail, the student should be made aware of the relationship between triglycerides and obesity.   |   |
| 1.7.  | describe the structure of phospholipids and their role in membrane structure and function;  | Relate structure to properties and hence to function.  |   |
| 1.8.  | describe the generalised structure of an amino acid, and the formation and breakage of a peptide bond;                                    |  |   |
| 1.9.  | <i>carry out tests for reducing and non-reducing sugars, starch, lipids and proteins;</i>   | <i>Benedict's test, KI/I<sub>2</sub> test, emulsion test, Biuret test.</i>   | <i>Investigate and compare quantitatively reducing sugars and starch.</i> |
| 1.10. | compare the different levels of protein structures; and,  | Primary, secondary, tertiary and quaternary.   |   |
| 1.11. | outline the molecular structure of haemoglobin, as an example of a globular protein, and of collagen, as an example of a fibrous protein. | Ensure that the relationships between their structures and functions are clearly established.  |   |



## UNIT 1

### MODULE 1: CELL AND MOLECULAR BIOLOGY (cont'd)

SPECIFIC OBJECTIVES	EXPLANATORY NOTES	SUGGESTED PRACTICAL ACTIVITIES
<b>2. Cell Structure and Functions</b>		
Students should be able to:		
2.1. compare the structures and functions of typical animal and plant cells as seen under the light and electron microscope;	Differences between electron and light microscope and between resolution and magnification.  Rough and smooth endoplasmic reticulum, Golgi body, mitochondria, ribosomes, lysosomes, chloroplasts, cell membrane, nuclear envelope, centrioles, nucleus and nucleolus.	Clear <i>diagrams</i> required. Describe and interpret <i>diagrams</i> and electron micrographs of the structure of membrane systems and organelles of typical animal and plant cells.
2.2. describe the structure of a prokaryotic cell;		<i>Electron micrograph of prokaryotic cell.</i>
2.3. compare the structure of prokaryotic cells with that of eukaryotic cells; and,	The basis of the endosymbiotic development of eukaryotic cells. <i>Can mention plants, animals, fungi and protista.</i>	
2.4. explain the concepts of tissue and organ using the dicotyledonous root and stem.	Use of transverse section of a dicotyledonous root and stem to illustrate tissues including parenchyma, xylem and phloem. The root is used as an organ.	Make plan and <i>detailed diagrams</i> to show the distribution of tissues within an organ of the dicotyledonous root and stem. The use of live specimen is encouraged, for example, Coleus.

## UNIT 1

### MODULE 1: CELL AND MOLECULAR BIOLOGY (cont'd)

SPECIFIC OBJECTIVES	EXPLANATORY NOTES	SUGGESTED PRACTICAL ACTIVITIES
<b>3. Membrane Structure and Function</b>		
Students should be able to:		
3.1. explain the Fluid Mosaic Membrane model of biological membrane structure; and,	The roles of phospholipids, cholesterol, glycolipids, protein and glycoproteins. Diagrams are required.	
3.2. explain the processes of diffusion, facilitated diffusion, osmosis, active transport, endocytosis and exocytosis.	Emphasis on the distinction between diffusion and osmosis; and active and passive processes. Diagrams are required. No calculations will be set on water potential.	Investigate the effects on plant cells immersion into solutions of different water potentials, <i>for example, red onion epidermal cells.</i>
<b>4. Enzymes</b>		
Students should be able to:		
4.1. explain that enzymes are globular proteins that catalyse metabolic reactions;	Definition of metabolism, anabolism and catabolism required.	
4.2. explain the mode of action of enzymes in terms of an active site, enzyme and/or substrate complex, lowering of activation energy and enzyme specificity;	Properties of enzymes. <i>Lock and key hypothesis, and</i> Induced-fit hypothesis.	

## UNIT 1

### MODULE 1: CELL AND MOLECULAR BIOLOGY (cont'd)

SPECIFIC OBJECTIVES	EXPLANATORY NOTES	SUGGESTED PRACTICAL ACTIVITIES
---------------------	-------------------	--------------------------------

#### Enzymes (cont'd)

Students should be able to:

- |      |  |  |   |
|------|--|--|---|
| 4.3. | explain the effects of pH, temperature, enzyme concentration, and substrate concentration on enzyme action; and, | Construction and interpretation of graphs.   | Investigate the effects of temperature and substrate concentration on enzyme-catalysed reactions, and explain these effects. <i>For example, use yeast and respiration. Use of virtual labs (see link below).</i> |
| 4.4. | discuss the effects of competitive and non-competitive inhibitors on enzyme activity.                            | Use of succinic dehydrogenase, <i>antabuse</i> and <i>organophosphates</i> as examples of enzyme inhibitors. |   |

#### Suggested Teaching and Learning Activities

To facilitate students' attainment of the objectives of this Module, teachers are advised to engage students in the teaching and learning activities listed below.

1. Allow students to use laboratory exercises to reinforce concepts taught rather than as a separate activity.
2. Encourage students to incorporate the use of online resources, such as videos, to visualise concepts.
2. Allow students to use multimedia and 3-dimensional models to assist in conceptualising cell and/or molecular structure.
3. *Allow students to view models of macromolecules using the molecular visualisation software.*
4. *Allow students to use virtual labs to illustrate enzymatic activity.*

## UNIT 1

### MODULE 1: CELL AND MOLECULAR BIOLOGY (cont'd)

#### RESOURCES

- Boyle, M., Senior, K. *Biology*. London: Harper Collins Publishers, 2008.
- Bradfield, P. *AS Level Biology*. Essex: Pearson Education Limited, 2001.
- Clegg, C J *Biology*. London: Hodder Education, 2014.
- Durant, Claire *Biology for CAPE® Examinations*. London: Macmillan Education, 2013.
- Fosbery, R., LaPlace, S. and McPherson, L. *CAPE Biology, A CXC® Study Guide*. Oxford University Press, 2012.
- Ramesar, M., Jones, M., Jones, G. *Biology Unit 1*. London: Cambridge University Press, 2011.

#### WEBSITES

Biology Mad: [www.biologymad.com/](http://www.biologymad.com/)

Xtreme Papers: [www.xtremepapers.com/](http://www.xtremepapers.com/)

[http://glencoe.mheducation.com/sites/dl/free/0078802849/383930/BL\\_11.html](http://glencoe.mheducation.com/sites/dl/free/0078802849/383930/BL_11.html) virtual lab - investigating the effect of pH and substrate concentration on enzyme activity

<http://www.biotopics.co.uk/jsmol/glucose.html>

## UNIT 1

### MODULE 2: GENETICS, VARIATION AND NATURAL SELECTION

#### GENERAL OBJECTIVES

On completion of this Module, students should:

1. understand the structure of nucleic acids and their roles in protein synthesis and nuclear division;
2. understand the behaviour of chromosomes, nucleus and cytoplasm in mitotic and meiotic cell division and their importance for stability and variation in a species;
3. understand the patterns of inheritance;
4. understand selected aspects of genetic engineering and its medical, agricultural, environmental, ethical and social implications; and,
5. understand the genetic basis of variation and its importance in natural selection.

#### SPECIFIC OBJECTIVES

#### EXPLANATORY NOTES

#### SUGGESTED PRACTICAL ACTIVITIES

##### 1. Structure and Roles of Nucleic Acids

Students should be able to:

- |      |   |   |
|------|---|---|
| 1.1. | compare the structure of RNA and DNA;   | Draw a nucleotide using shapes; recognise (not draw) the structural formulae of nucleotides, ribose, deoxyribose, pyrimidines, purines; nature of hydrogen bonds. |
| 1.2. | explain the importance of hydrogen bonds and base pairing in DNA replication; | Recognition of the significance of 5' and 3'; semiconservative replication; genetic code.   |
| 1.3. | describe the roles of DNA and RNA in protein synthesis;                       | Different types of RNA (tRNA, rRNA and mRNA) and their respective roles. Initiation, transcription, translation, termination.                                     |

## UNIT 1

### MODULE 2: GENETICS, VARIATION AND NATURAL SELECTION (cont'd)

SPECIFIC OBJECTIVES	EXPLANATORY NOTES	SUGGESTED PRACTICAL ACTIVITIES
---------------------	-------------------	--------------------------------

#### Structure and Roles of Nucleic Acids (cont'd)

Students should be able to:

- 1.4. explain the relationship between the sequence of nucleotides and the amino acid sequence in a polypeptide; and,
- 1.5. explain the relationship between the structure of DNA, protein structure and the phenotype of an organism.

#### 2. Cell Division and Variation

Students should be able to:

- 2.1. describe the relationship among DNA, chromatin, and chromosomes;
- 2.2. describe with the aid of diagrams, the stages of mitotic cell division;
- 2.3. explain the importance of DNA replication for maintaining genetic stability;
- 2.4. discuss the role and importance of mitosis in growth, repair and asexual reproduction;

Inclusion of interphase.

Observe the stages in the cell cycle and make annotated *diagrams* from prepared slides, and/or a freshly prepared *squashed* root tip to show the stages of mitosis.

## UNIT 1

### MODULE 2: GENETICS, VARIATION AND NATURAL SELECTION (cont'd)

SPECIFIC OBJECTIVES	EXPLANATORY NOTES	SUGGESTED PRACTICAL ACTIVITIES
<b>Cell Division and Variation (cont'd)</b>		
Students should be able to:		
2.5. describe with the aid of diagrams, the processes involved in meiotic cell division;	Students should be familiar with the terms: homologous chromosomes, haploid and diploid. Inclusion of crossing over, alignment of chromosomes at metaphase, random segregation at anaphase. Names of the intermediate stages of meiosis not required.	Construct models to demonstrate chromosome behaviour in meiosis. Pipe cleaners, plastic wire, embroidery thread, Bristol board may be used for modelling chromosome behaviour in meiosis – biodegradable materials not recommended.
2.6. discuss how meiosis contributes to heritable variation;	Comparison with the process of mitosis.	Use prepared slides of testes <i>and/or anther</i> to demonstrate the stages of meiosis.
2.7. explain why sexually produced organisms vary in characteristics;		
2.8. describe gene and chromosome mutations;	Include the types of gene and chromosome mutations.	
2.9. discuss the implications of changes in DNA nucleotide sequence for cell structure and function in sickle cell anaemia;		
2.10. explain how mutation brings about genetic variation; and,	Not limited to: sickle-cell anaemia, cystic fibrosis, PKU and Down Syndrome.	
2.11. explain why heritable variation is important to selection.		



## UNIT 1

### MODULE 2: GENETICS, VARIATION AND NATURAL SELECTION (cont'd)

SPECIFIC OBJECTIVES	EXPLANATORY NOTES	SUGGESTED PRACTICAL ACTIVITIES
<b>3. Patterns of Inheritance</b>		
Students should be able to:		
3.1. use genetic diagrams to solve problems involving monohybrid and dihybrid crosses;	Gene, allele, dominant, recessive, codominant, homozygous, heterozygous, sex linkages, codominance, multiple alleles, and dominant epistasis. Candidates should understand the ratios.	Analyse seed samples of peas for Mendelian dihybrid ratio.
3.2. analyse the results of a genetic cross by applying the Chi-square test; and,	Formulae will be given. Set out data in tabular form.	
3.3. determine whether the difference between the observed and expected ratio is significant using the results of the Chi-square test.	The concept of probability. Explanation of the use of 0.05 confidence limits and the null hypothesis.	
<b>4. Aspects of Genetic Engineering</b>		
Students should be able to:		
4.1. outline the principles of restriction enzyme use to “cut” sections of DNA and ligase enzyme to “paste” DNA together;	Restriction enzymes as “molecular scissors” and ligase enzyme as “molecular glue”. Importance of these classes of enzymes in development of R-DNA technology. <i>Mention advanced genome editing tools, such as CRISPR-Cas9.</i>	

## UNIT 1

### MODULE 2: GENETICS, VARIATION AND NATURAL SELECTION (cont'd)

SPECIFIC OBJECTIVES	EXPLANATORY NOTES	SUGGESTED PRACTICAL ACTIVITIES
---------------------	-------------------	--------------------------------

#### Aspects of Genetic Engineering (cont'd)

Students should be able to:

- |      |  |   |
|------|--|---|
| 4.2. | explain the basic steps involved in recombinant DNA (rDNA) technology;                               | <i>An overview of the process including the isolation of genes; cloning of genes; vectors. Use examples including insulin production.</i> |
| 4.3. | discuss the successes and challenges of gene therapy in modern medicine; and,                        | Concept of gene therapy. Use case study examples including cystic fibrosis.   |
| 4.4. | discuss the implications of the use of genetically modified organisms on humans and the environment. | Medical, agricultural, ethical and social implications.   |

#### 5. Natural Selection

Students should be able to:

- |      |   |  |
|------|---|--|
| 5.1. | explain how environmental factors act as forces of natural selection;             | Examples such as resistance to antibiotics, <i>Biston betularia</i> (peppered moth), <i>the Trinidadian guppies</i> and <i>the Dominican anole</i> . |
| 5.2. | explain how natural selection may be an agent of constancy or an agent of change; | Directional, disruptive, and stabilising selection; knowledge of appropriate graphs is required.   |
| 5.3. | discuss natural selection as a mechanism of evolution;                            | Darwin's theory, its observations and conclusions.   |

## UNIT 1

### MODULE 2: GENETICS, VARIATION AND NATURAL SELECTION (cont'd)

SPECIFIC OBJECTIVES	EXPLANATORY NOTES	SUGGESTED PRACTICAL ACTIVITIES
---------------------	-------------------	--------------------------------

#### Natural Selection (cont'd)

Students should be able to:

- |      |  |  |
|------|--|--|
| 5.4. | discuss the biological species concept; and, | Discussion of the limitations of this concept, for example, in breeding.   |
| 5.5. | explain the process of speciation.           | Isolating mechanisms – reproductive, geographic, behavioural and temporal, allopatric and sympatric speciation with reference to two named examples. |

#### Suggested Teaching and Learning Activities

To facilitate students' attainment of the objectives of this Module, teachers are advised to engage students in the teaching and learning activities listed below.

1. Allow students to attempt several exercises with the mathematical aspects of Biology in order to gain familiarity and to appreciate the levels of significance.
2. Have students conduct review of literature on biodiversity and conservation, *and make presentation to the class.*
3. Invite resource personnel to do presentation on plant biotechnology.
4. Engage students in a discussion of how humans use artificial selection to create, for example, domesticated animals, different breeds of dogs, chickens that lay a lot of eggs, Barbados Blackbelly sheep, and Jamaica Hope.

## UNIT 1

### MODULE 2: GENETICS, VARIATION AND NATURAL SELECTION (cont'd)

#### RESOURCES

Teachers and students may find reference to the following resource materials useful. The latest editions are recommended.

Boyle, M., Senior, K.	<i>Biology</i> . London: Harper Collins Publishers, 2008.
Bradfield, P.	<i>AS Level Biology</i> . Essex: Pearson Education Limited, 2001.
Clegg, C. J.	<i>Biology</i> . London: Hodder Education, 2014.
Durant, Claire	<i>Biology for CAPE® Examinations</i> . London: Macmillan Education, 2013.
Fosbery, R., LaPlace, S. and McPherson, L.	<i>CAPE Biology, A CXC® Study Guide</i> . Oxford University Press, 2012.
Ramesar, M., Jones, M., Jones, G.	<i>Biology Unit 1</i> . London: Cambridge University Press, 2011.

#### WEBSITES

Gene Therapy Case Studies: <http://learn.genetics.utah.edu/>

Conservation International Website <https://www.conservation.org/>

<http://darwin-online.org.uk/>

<https://www.nap.edu/read/5787/chapter/1>

National Geographic Magazine website <https://www.nationalgeographic.com/magazine/>

PBS Evolution website [www.pbs.org/wgbh/evolution/darwin/](http://www.pbs.org/wgbh/evolution/darwin/)

Video and/or Television materials such as those found on the Discovery Channel

<https://merlot.com/>

<https://www.nap.edu/catalog/5787/teaching-about-evolution-and-the-nature-of-science>

**UNIT 1**  
**MODULE 3: REPRODUCTIVE BIOLOGY**

**GENERAL OBJECTIVES**

On completion of this Module, students should:

1. understand sexual and asexual reproduction in plants; and,
2. understand sexual reproduction in humans.

SPECIFIC OBJECTIVES	EXPLANATORY NOTES	SUGGESTED PRACTICAL ACTIVITIES
<b>1. Reproduction in Plants</b>		
Students should be able to:		
1.1. describe the structure of the anther and the formation of pollen grains;	Annotated diagrams required.	
1.2. describe the structure of the ovule and the formation of the embryo sac;	Annotated diagrams required.	Make drawings of the anther and embryo sac from prepared slides.
1.3. explain the sequence of events from pollination to fertilization;	Annotated diagrams required.	
1.4. explain how cross-fertilization is promoted;	Non-synchronous maturation of stamens (protogyny) and carpels (protandry), separate sexes (dioecy), insect pollination, self-incompatibility, and sterility.	
1.5. discuss the genetic consequences of sexual reproduction;	Self-fertilization and cross fertilization.	
1.6. explain the significance of double fertilization in the embryo sac;		

## UNIT 1

### MODULE 3: REPRODUCTIVE BIOLOGY (cont'd)

#### SPECIFIC OBJECTIVES

#### EXPLANATORY NOTES

#### SUGGESTED PRACTICAL ACTIVITIES

#### Reproduction in Plants (cont'd)

Students should be able to:

- |      |   |  |
|------|---|--|
| 1.7. | discuss the development of the seed and the fruit from the embryo sac and its contents, the ovule and the ovary; and, | Types of fruits not required.  |
| 1.8. | <i>discuss the advantages and disadvantages of asexual reproduction.</i>  | Explanation of the term asexual reproduction. Relate binary fission, budding, asexual spore formation, fragmentation to asexual reproduction in plants, for example, ginger, meristems, hormone stimulation, details of the processes involved in tissue culture and the production of cuttings. |

#### 2. Sexual Reproduction in Humans

Students should be able to:

- |      |   |   |   |
|------|---|---|---|
| 2.1. | describe the structure and function of the male and female reproductive systems;                                    | Annotated diagrams required.  | Make drawings from prepared slides of the mammalian ovary and testis. |
| 2.2. | explain gametogenesis and the role of hormones in this process;   | The differences between the secondary oocyte and ovum. Include oogenesis and spermatogenesis. |   |
| 2.3. | discuss how the structure of the ovum and the sperm facilitate their functional roles in the fertilization process; | Comparison of the structure of the ovum and the sperm. Use annotated diagrams.                |   |



## UNIT 1

### MODULE 3: REPRODUCTIVE BIOLOGY (cont'd)

SPECIFIC OBJECTIVES	EXPLANATORY NOTES	SUGGESTED PRACTICAL ACTIVITIES
<b>Sexual Reproduction in Humans (cont'd)</b>		
Students should be able to:		
2.4. describe the basic process of fertilization;	How and where the process occurs.	
2.5. describe implantation as it relates to reproduction;	Relate to the menstrual cycle in Specific Objective 2.6.	
2.6. <i>discuss the importance of hormones in the menstrual cycle;</i>	Emphasis on the principle of negative feedback mechanisms.	
2.7. discuss how knowledge of human reproductive anatomy and physiology has been applied to the development of contraceptive methods;		
2.8. explain the structure and functions of the placenta;		
2.9. discuss the functions of the amnion; and,		
2.10. discuss the possible effects of maternal behaviour on foetal development.	<i>The role of nutrition, the influence of alcohol and cigarette smoking, use of legal and/or illicit drugs. Pre-natal monitoring programs.</i>	

## UNIT 1

### MODULE 3: REPRODUCTIVE BIOLOGY (cont'd)

#### Suggested Teaching and Learning Activities

To facilitate students' attainment of the objectives of this Module, teachers are advised to engage students in the teaching and learning activities listed below.

1. Have students examine a range of floral structures in order to appreciate the variation in pollination methods.
2. Invite resource personnel to do presentation on human reproduction, *pre-natal care*, and *substance abuse*.
3. Arrange visits to appropriate family planning centres, biotechnology Labs, plant propagation stations and tissue culture units.

#### RESOURCES

Teachers and students may find reference to the following resource materials useful. The latest editions are recommended.

Boyle, M., Senior, K.	<i>Biology</i> . London: Harper Collins Publishers, 2008.
Bradfield, P.	<i>AS Level Biology</i> . Essex: Pearson Education Limited, 2001.
Carrington, S	<i>Wild Plants of Barbados</i> . London and Basingstoke: Macmillan Press Limited, 2007.
Clegg, C J	<i>Biology</i> . London: Hodder Education, 2014.
Durant, Claire	<i>Biology for CAPE® Examinations</i> . London: Macmillan Education, 2013.
Fosbery, R., LaPlace, S. and McPherson, L.	<i>CAPE Biology, A CXC® Study Guide</i> . Oxford University Press, 2012.
Ramesar, M., Jones, M., Jones, G.	<i>Biology Unit 1</i> . London: Cambridge University Press, 2011.
Taylor, D.	<i>Growth Development and Reproduction</i> . Cambridge: Cambridge University Press Advanced Sciences, 2001.



**UNIT 1**  
**MODULE 3: REPRODUCTIVE BIOLOGY (cont'd)**

**WEBSITES**

Biology Mad: <http://www.biologymad.com/>

Xtreme Papers: <http://www.xtremepapers.com/>

◆ **UNIT 2: BIOENERGETICS, BIOSYSTEMS AND APPLICATIONS**  
**MODULE 1: BIOENERGETICS AND CONSERVATION**

**GENERAL OBJECTIVES**

On completion of this Module, students should:

1. understand the process of photosynthesis, its role in transforming light energy and the effects of the limiting factors on plant productivity;
2. understand the process of cellular respiration and its role in producing Adenosine Triphosphate (ATP);
3. understand energy flow and nutrient cycling in ecosystems and their role in maintaining the stability of these ecosystems;
4. appreciate the ecosystem as a dynamic system involving different types of interactions between biotic and abiotic components;
5. understand how different types of diversity contribute to overall biodiversity; and,
6. develop an appreciation of conservation practices.

**SPECIFIC OBJECTIVES**

**EXPLANATORY NOTES**

**SUGGESTED PRACTICAL ACTIVITIES**

**1. Photosynthesis and ATP Synthesis**

Students should be able to:

- |   |   |   |
|---|---|---|
| <p>1.1. relate the structure of a dicotyledonous leaf, a palisade cell and a chloroplast to their roles in the process of photosynthesis;</p> | <p>Annotated diagrams required.</p>   | <p><i>Make diagrams</i> from prepared slides of a transverse section of a dicotyledonous leaf, and a palisade cell.</p> |
| <p>1.2. explain the process of photophosphorylation with respect to photosynthetic electron transport;</p>                                    | <p>ATP's functions as the universal energy "currency" in all living organisms. Include the role of pigments, electron carriers and the establishment of proton gradients across thylakoid membranes in the process.</p> |   |

## UNIT 2

### MODULE 1: BIOENERGETICS AND CONSERVATION (cont'd)

#### SPECIFIC OBJECTIVES

#### EXPLANATORY NOTES

#### SUGGESTED PRACTICAL ACTIVITIES

#### Photo Synthesis and ATP Synthesis (cont'd)

Students should be able to:

- 1.3. outline the essential stages of the Calvin cycle involving the light independent fixation of carbon dioxide;

The conversion of light energy into chemical energy of ATP, the reduction of NADP and the evolution of oxygen as a by-product should be noted. No biochemical detail is required. Knowledge of C4 plants not required. Include the fixation of carbon dioxide by ribulose biphosphate to yield phosphoglyceric acid (glycerate-3-P) and the subsequent conversion to triose phosphate and other carbohydrates. Emphasise the roles of ATP and NADP.

- 1.4. discuss the concept of limiting factors in photosynthesis; and,

*Design and/or* investigate the effect of limiting factors on the rate of photosynthesis.

- 1.5. discuss how knowledge of these limiting factors can be applied to the improvement of plant productivity.

Light intensity and carbon dioxide concentration. Green house technology, wilting, *hydroponics*, growth chambers.

## UNIT 2

### MODULE 1: BIOENERGETICS AND CONSERVATION (cont'd)

SPECIFIC OBJECTIVES	EXPLANATORY NOTES	SUGGESTED PRACTICAL ACTIVITIES
<b>2. Cellular Respiration and ATP Synthesis</b>		
Students should be able to:		
2.1. explain the sequence of steps in glycolysis;	Explanation of the stepwise breakdown of glucose in cellular respiration; Names of enzymes not required. Include the initial phosphorylation of glucose, lysis into two 3-carbon compounds and the subsequent production of pyruvate, a small yield of ATP and reduced NAD. Recognition of simplified structural formulae intermediate.	
2.2. describe the structure of a mitochondrion, relating its structure to its function;	Include annotated diagrams.	
2.3. state the fate of pyruvate in the cytosol when oxygen is available;	Pyruvate enters the matrix and is converted to acetyl CoA via oxidative decarboxylation.	<i>Design and/or</i> investigate the rate of oxygen uptake during respiration using a simple respirometer.
2.4. explain the significance of the Krebs cycle in ATP formation;	Explanation of the Krebs Cycle. Details of structures of intermediates not required. Emphasise production of NADH and FADH <sub>2</sub> ; oxidation and decarboxylation.	

## UNIT 2

### MODULE 1: BIOENERGETICS AND CONSERVATION (cont'd)

#### SPECIFIC OBJECTIVES

#### EXPLANATORY NOTES

#### SUGGESTED PRACTICAL ACTIVITIES

#### Cellular Respiration and ATP Synthesis (cont'd)

Students should be able to:

- 2.5. explain the process of oxidative phosphorylation with reference to the electron transport chain; and, *Including the roles of hydrogen and electron carriers; the proton gradient, the synthesis of ATP using ATP synthase and the role of oxygen. No details of the carriers are required. A summary of ATP production should be known.*
- 2.6. compare the fate of pyruvate in the absence of oxygen in animals and yeast. *Fermentation allows for the regeneration of NAD so that glycolysis can continue in the absence of oxygen. Include the concept of oxygen debt in mammals; and note that lactate can be converted back (oxidised) to pyruvate when oxygen is again available. Include commercial uses of yeast.*

#### 3. Energy Flow and Nutrient Cycling

Students should be able to:

- 3.1. discuss the efficiency of energy transfer between trophic levels; *Revision of the terms: ecosystem, habitat, ecological niche, food chains and food webs. Emphasise the advantages of the food web.*
- 3.2. discuss the concept of biological pyramids; *Including the limitations of the pyramids of numbers, biomass and energy. Construct pyramids of energy using quantitative data.*

## UNIT 2

### MODULE 1: BIOENERGETICS AND CONSERVATION (cont'd)

#### SPECIFIC OBJECTIVES

#### EXPLANATORY NOTES

#### SUGGESTED PRACTICAL ACTIVITIES

#### Energy Flow and Nutrient Cycling (cont'd)

Students should be able to:

- |      |  |   |
|------|--|---|
| 3.3. | describe how nitrogen is cycled within an ecosystem; and,  | The role of microorganisms.   |
| 3.4. | explain how energy flow and nutrient cycling are important for ecosystems to remain self-sustaining units. | Distinction between energy flow and nutrient cycling within an ecosystem. |

#### 4. Ecological Systems, Biodiversity and Conservations

Students should be able to:

- |      |   |  |  |
|------|---|--|--|
| 4.1. | discuss how ecosystems function as dynamic systems;   | Use of a named example. Include biotic and abiotic factors and the interactions between them. Mention the terms competition, predation, mutualism, commensalism, and parasitism. | <i>The use of models to study ecosystems, for example, mesocosm.</i> |
| 4.2. | explain the concept of biodiversity;  | Discussion of genetic diversity, species diversity and ecosystem diversity.  |  |
| 4.3. | discuss the importance of the maintenance of biodiversity;  | Intrinsic, direct and indirect values, including medicine, natural products, tourism.  |  |
| 4.4. | discuss how species diversity is related to the stability of an ecosystem; and,                       | Discussion of factors important to maintaining species diversity. Use regional examples.   |  |
| 4.5. | explain how <u>in situ</u> and <u>ex situ</u> conservation methods are used to maintain biodiversity. | Protected areas and reserves, seed banks, botanic gardens, zoos, sperm banks, embryo banks.  |  |

## UNIT 2

### MODULE 1: BIOENERGETICS AND CONSERVATION (cont'd)

#### Suggested Teaching and Learning Activities

To facilitate students' attainment of the objectives of this Module, teachers are advised to engage students in Practical Activities outlined below.

1. Have student conduct review of the general principles of oxidation, reduction and electron flow.
2. Incorporate the use of charts and creation of concept maps rather than excessive biochemical details.
3. To assist students in appreciating ecosystem dynamics, use multimedia presentations and online resources such as Nature, National Geographic and Discovery.
4. *To demonstrate biodiversity and conservation in the form of large-scale, man-made biomes, refer students to the Eden Project in the United Kingdom.*
5. Organise fieldtrips or fieldwork to include the use of sampling techniques and measurement of abiotic factors.
6. Engage students in discussion on the human impact on biodiversity and conservation.
7. *Arrange visits to reserves, seedbanks or botanical gardens. Please note that all of these facilities play key roles in plant conservation.*
8. *Use animations and other online resources to help students visualise various processes.*
9. *Use of Global Artificial Photosynthesis (GAP) and its role in environmental sustainability.*
10. *Compare the species diversity of two habitats using biodiversity indices.*

#### RESOURCES

Teachers and students may find reference to the following resource materials useful. The latest editions are recommended.

Durant, Claire

*Biology for Cape Unit 2, A CXC® Study Guide.*  
Oxford University Press, 2014.

Reiss, M. and Chapman, J.

*Ecology: Principles and Applications.* Cambridge:  
Cambridge University Press, 2003.

## UNIT 2

### MODULE 1: BIOENERGETICS AND CONSERVATION (cont'd)

#### WEBSITES

<https://www.savethemanatee.org/>

<https://www.ramsar.org/>

<https://www.wetlands.org/>

[http://www.grupojaragua.org.do/index\\_english.html](http://www.grupojaragua.org.do/index_english.html)

<https://www.nap.edu/read/9589/chapter/1>

*Highered McGraw Hill Animations -*

<http://highered.mheducation.com/olc/dl/120060/ravenanimation.html> - *Chapters 9 and 10*



**UNIT 2**  
**MODULE 2: BIOSYSTEMS MAINTENANCE**

**GENERAL OBJECTIVES**

On completion of this Module, students should:

1. understand the mechanisms by which plants absorb minerals and water and the impact of environmental factors on these mechanisms;
2. understand translocation in relation to structure of the phloem;
3. understand the organisation, structure, transport function, and internal control mechanisms of the mammalian circulatory system;
4. understand and apply the concept of homeostasis and hormonal action using named examples;
5. understand the role of the kidneys as excretory and regulatory organs and their impact in common disorders; and,
6. understand the role of the nervous system in systems maintenance.

**SPECIFIC OBJECTIVES**

**EXPLANATORY NOTES**

**SUGGESTED PRACTICAL ACTIVITIES**

**1. The Uptake and Transport of Water and Minerals**

Students should be able to:

- |      |  |  |  |
|------|--|--|--|
| 1.1. | explain the uptake of ions by active transport in roots;                         | Emphasis on the role of the endodermis.  |  |
| 1.2. | describe the entry of water into plant roots in terms of water potential;        |  |  |
| 1.3. | relate the structure of xylem vessels to their function;                         | Inclusion of transport and support roles.  | Make <i>diagrams</i> from prepared slides of xylem vessels.  |
| 1.4. | <i>explain</i> the ascent of water in plants; and,                               | Root pressure, capillarity, cohesion, adhesion and transpiration pull. Include the role of stomata in transpiration. | <i>Wet mounts of celery placed in coloured fluid could be observed. Use Coleus epidermal peels to visualise stomata.</i> |
| 1.5. | <i>discuss</i> the impact of environmental factors on the rate of transpiration. | Light and air movements. Root pressure, capillarity, cohesion, adhesion.   | <i>Design an activity to investigate the effects of environmental factors on</i>   |

*the rate of transpiration.*

## UNIT 2

### MODULE 2: BIOSYSTEMS MAINTENANCE (cont'd)

SPECIFIC OBJECTIVES	EXPLANATORY NOTES	SUGGESTED PRACTICAL ACTIVITIES
<b>2. Transport in the Phloem</b>		
Students should be able to:		
2.1. relate the structure of sieve tubes and companion cells to their function;	Label pertinent features in an electron micrograph of a sieve tube and companion cell.	Make <i>diagrams</i> of sieve tubes and companion cells from prepared microscope slides.
2.2. explain how phloem loading in the leaves occurs against a concentration gradient; and,		
2.3. discuss the mass (pressure) flow hypothesis as a possible mechanism of translocation.	Experimental evidence for and against this hypothesis.	
<b>3. The Circulatory System of Mammals</b>		
Students should be able to:		
3.1. <i>describe the structure of the heart, arteries, veins, capillaries, erythrocytes, and leucocytes, relating their structures to their functions</i>	<i>Use fresh or preserved specimens (to emphasise the 3-D structure); prepare annotated drawings.</i>	<i>Make drawings of whole mount and/or longitudinal sections of the heart. Prepare diagrams of arteries, veins, erythrocytes, and leucocytes from prepared microscope slides.</i>
3.2. explain the cardiac cycle and its initiation;		
3.3. discuss the internal factors that control heart action;		
3.4. discuss factors affecting blood pressure;	Definition of the terms blood pressure and pulse.	<i>Measurements before and after exercise.</i>



## UNIT 2

### MODULE 2: BIOSYSTEMS MAINTENANCE (cont'd)

#### SPECIFIC OBJECTIVES

#### EXPLANATORY NOTES

#### SUGGESTED PRACTICAL ACTIVITIES

#### The Circulatory System of Mammals (cont'd)

Students should be able to:

- |      |   |                           |
|------|---|---------------------------|
| 3.5. | explain the role of haemoglobin in oxygen and carbon dioxide transport;                               | Flow charts not required. |
| 3.6. | describe oxygen dissociation curves for adult haemoglobin; and,                                       | Interpretation of data.   |
| 3.7. | explain the significance of the effect of carbon dioxide on oxygen dissociation curves (Bohr Effect). |                           |

#### 4. Homeostasis and Hormonal Action

Students should be able to:

- |      |  |  |   |
|------|--|--|---|
| 4.1. | discuss the concept homeostasis;   | Receptors, effectors, set point, feedback, and homeostatic equilibrium. Emphasise the dynamics of feedback mechanisms. |   |
| 4.2. | outline the general principles of hormonal action in animals;                | Ductless glands in animals; target cells and receptors.  |   |
| 4.3. | explain how insulin and glucagon regulate blood glucose concentration;       |  |   |
| 4.4. | discuss the commercial use made of ethylene in supplying market-ready fruit. | Mention the gaseous nature of ethylene and its effect on respiration. Types of fruits not required.                    | <i>Simple experimental with relevant control using fresh fruit only versus fresh and ripening fruit to demonstrate the effect of ethylene (ethene) on fruit ripening.</i> |

## UNIT 2

### MODULE 2: BIOSYSTEMS MAINTENANCE (cont'd)

SPECIFIC OBJECTIVES	EXPLANATORY NOTES	SUGGESTED PRACTICAL ACTIVITIES
---------------------	-------------------	--------------------------------

#### Homeostasis and Hormonal Action (cont'd)

Students should be able to:

#### 5. The Kidney, Excretion and Osmoregulation

Students should be able to:

- |      |  |  |  |
|------|--|--|--|
| 5.1. | explain the need to remove nitrogenous and other excretory products from the body;                                 | Revision of the formation of urea.   |  |
| 5.2. | describe the gross structure of the kidney and the detailed structure of the nephron and associated blood vessels; | Annotated diagrams required.   | Make <i>diagrams</i> of sections of the kidney from prepared sides.  |
| 5.3. | explain the function of the kidney in terms of excretion and osmoregulation; and,                                  | <i>Include the role of ADH. Mention the clinical significance of glucose and protein in the urine.</i> | <i>Student investigation of prepared solutions simulating urine samples of different compositions. Appropriate activity for Planning and Design.</i> |
| 5.4. | discuss the clinical significance of the presence of glucose and protein in the urine.                             |  |  |

#### 6. Nervous Co-ordination

Students should be able to:

- |      |   |                              |  |
|------|---|------------------------------|--|
| 6.1. | describe the structure of motor and sensory neurons;  | Annotated diagrams required. |  |
| 6.2. | explain the role of nerve cell membranes in establishing and maintaining the resting potential; |                              |  |

## UNIT 2

### MODULE 2: BIOSYSTEMS MAINTENANCE (cont'd)

SPECIFIC OBJECTIVES	EXPLANATORY NOTES	SUGGESTED PRACTICAL ACTIVITIES
---------------------	-------------------	--------------------------------

#### Nervous Co-ordination (cont'd)

Students should be able to:

- |      |   |  |
|------|---|--|
| 6.3. | describe the conduction of an action potential along the nerve cell membrane; | The value of myelinated neurons in increasing the speed of transmission. |
| 6.4. | explain synaptic transmission; and,   | Structure of cholinergic synapse. Annotated diagrams required.           |
| 6.5. | outline the role of synapses.   |  |

#### Suggested Teaching and Learning Activities

To facilitate students' attainment of the objectives of this Module, teachers are advised to engage students in teaching and learning activities listed below.

1. Ask students to make slides of transverse and longitudinal sections of stems, roots and leaves from living tissue, selected by the students to investigate their microscopic structure.
2. Allow students to use binocular microscopes to examine root hairs and stomata.
3. Set up experiments on transpiration in both cut stems and potted plants to show methods and results.
4. Allow students to take blood pressure measurements, and investigate the effect of exercise, rest, excitement, and temperature on blood pressure.
5. Use models of the heart and kidney to help students to conceptualise 3-dimensional structures.
6. Encourage students to make scaled models of xylem, phloem, sections of Bowman's Capsules, nephrons, alveoli, arteries, veins and blood components.
7. Use multimedia, and visit Websites using keywords and keep a record and or bookmarks of useful sites.
8. Allow or assist students to take photographs of microscope slides and make presentation slides.

## UNIT 2

### MODULE 2: BIOSYSTEMS MAINTENANCE (cont'd)

#### RESOURCES

Teachers and students may find reference to the following resource materials useful. The latest editions are recommended.

Bradfield, P.	<i>A2 Level Biology</i> . Essex: Pearson Education Limited, 2001.
Durant, Claire	<i>Biology for Cape Unit 2, A CXC® Study Guide</i> . Oxford University Press, 2014.
Jones, A., Reed, R. and Weyers, J.	<i>Practical Skills in Biology, 3rd Edition</i> . New Jersey: Pearson Prentice Hall, Pearson Education Limited, 2016.
Indge, B.	<i>Data and Data Handling for AS and A2 Biology</i> . London: Hodder and Murray Publishers, 2003.
Morgan, S.	<i>Practical Work for Biology</i> . London: Hodder and Stroughton, 2002.

#### JOURNALS

Time, Newsweek, Nature, Discover

#### ELECTRONIC SOURCES

Insight Media Video & CD Rom Catalogue

#### WEBSITE

[www.insight-media.com](http://www.insight-media.com)

## UNIT 2

### MODULE 3: APPLICATIONS OF BIOLOGY

#### GENERAL OBJECTIVES

On completion of this Module, students should:

1. understand the terms 'health' and 'disease';
2. understand the principles of immunology;
3. be aware of the principles underlying social and preventative medicine; and,
4. understand biological and social implications of substance abuse.

SPECIFIC OBJECTIVES	EXPLANATORY NOTES	SUGGESTED PRACTICAL ACTIVITIES
<b>1. Health and Disease</b>		
Students should be able to:		
1.1. discuss the meaning of the term 'health';	Focus on the physical, mental and social aspects of health.	
1.2. explain the categories of disease or illness; and,	Physical, mental, social, chronic, infectious, degenerate, inherited, self-inflicted, deficiency, with an example of each. Diseases will fit into more than one category.	<i>Model the transmission of communicable or social diseases by using a hands-on simulation.</i>
1.3. analyse data involving incidence and mortality rates of disease.	Explanation of the meanings of incidence and mortality rates; students should interpret and analyse data, and draw conclusions and or make predictions.	

## UNIT 2

### MODULE 3: APPLICATIONS OF BIOLOGY (cont'd)

SPECIFIC OBJECTIVES	EXPLANATORY NOTES	SUGGESTED PRACTICAL ACTIVITIES
<b>2. Immunology</b>		
Students should be able to:		
2.1. define the term, “immune response”;		
2.2. distinguish between the humoral and the cell-mediated immune responses;	<i>Include the sequence of events involved in each response.</i>	
2.3. explain the role of memory cells in long-term immunity;	T- and B- memory cells.	
2.4. compare the origin and maturation of B- and T-lymphocytes;	Include the types of T-cells and their function (refer to HIV); B-cells and their function.	
2.5. describe the mode of action of phagocytes;	Revision of phagocytosis; include role of mast cells and histamine production; complement; phagocytes as antigen-presenting cells.	
2.6. relate the molecular structure of a typical antibody molecule to its function;	Use of labelled diagram of typical antibody showing its ‘Y- shaped’ structure; include the function of the various parts; specificity of antibody to antigen.	
2.7. state what is meant by a monoclonal antibody;		
2.8. describe the use of monoclonal antibodies in diagnosis and treatment;	The anticancer drug, MabThera; details required of the use of monoclonal antibodies in pregnancy testing.	



## UNIT 2

### MODULE 3: APPLICATIONS OF BIOLOGY (cont'd)

SPECIFIC OBJECTIVES	EXPLANATORY NOTES	SUGGESTED PRACTICAL ACTIVITIES
---------------------	-------------------	--------------------------------

#### Immunology (cont'd)

Students should be able to:

- |       |  |   |
|-------|--|---|
| 2.9.  | distinguish between active and passive immunity, natural and artificial immunity; and, | <i>Include examples for each type.</i>  |
| 2.10. | explain the role of vaccination in providing immunity.                                 | <i>Mention the successes and challenges of the use of vaccines to reduce the incidence of diseases.</i> |

#### 3. Social and Preventative Medicine

Students should be able to:

- |      |   |  |  |
|------|---|--|--|
| 3.1. | discuss the causative relationship among diet, obesity and diabetes;                                    | Revision of the concept of a balanced diet; Body Mass Index (BMI); Type 1 and Type 2 diabetes.   |  |
| 3.2. | describe the effects of fats on the cardiovascular system;  | Atherosclerosis, coronary heart disease, hypertension and stroke. Details of plaque formation.   |  |
| 3.3. | discuss the consequences of exercise on the body and the benefits of maintaining a physically fit body; | Long-term and short-term consequences; relate benefits to the prevention of chronic diseases; refer to VO <sub>2</sub> max and cardiac efficiency.   | Investigate the immediate effects of exercise on the body. |
| 3.4. | describe the mechanisms of infection for viral diseases and their causative agents;                     | Mention AIDS and dengue fever (in the Caribbean context). Include processes of infection, the biology of the virus; length of incubation period; replication of the disease-causing organisms. |  |



## UNIT 2

### MODULE 3: APPLICATIONS OF BIOLOGY (cont'd)

#### SPECIFIC OBJECTIVES

#### EXPLANATORY NOTES

#### SUGGESTED PRACTICAL ACTIVITIES

#### Social and Preventative Medicine (cont'd)

Students should be able to:

- 3.5. *explain the modes of transmission of HIV and dengue virus;*
- HIV: mention lifestyle, sexual intercourse, sharing needles or syringes, mother to child during pregnancy, birth or breastfeeding.*
- Dengue *virus*: the vector is *Aedes aegypti*.
- 3.6. discuss reasons for the regional distribution of Acquired Immune Deficiency Syndrome (AIDS), diabetes and cancer;
- AIDS: roles of lifestyle, ease of travel, cost of drugs, and lack of education on the spread of the virus.
- Diabetes: include the effects of diet, obesity, and prenatal malnutrition.
- Cancer: include roles of environmental hazards, food additives, viruses, genetic factors; implications of symptom awareness and failure to seek treatment in management of the disease.
- 3.7. assess the impact of communicable and non-communicable diseases regionally; and,
- Include social and economic issues. Use named examples.

## UNIT 2

### MODULE 3: APPLICATIONS OF BIOLOGY (cont'd)

#### SPECIFIC OBJECTIVES

#### EXPLANATORY NOTES

#### SUGGESTED PRACTICAL ACTIVITIES

#### Social and Preventative Medicine (cont'd)

Students should be able to:

- 3.8. discuss the roles of social, economic and biological factors in the prevention and control of viral infections.
- Infections including but not limited to AIDS and dengue fever.

#### 4. Substance Abuse

Students should be able to:

- 4.1. discuss the meaning of the term, "drug abuse";
- Emphasise that both legal and illegal drugs can be abused.*
- 4.2. distinguish between psychological and physical dependence;
- 4.3. describe the short-term and long-term consequences of alcohol consumption on the nervous system and the liver;
- Short-term – fatty liver, hepatitis; long-term – cirrhosis, cancer, impaired nervous transmission, demyelination, dehydration of the brain cells.
- 4.4. discuss the social consequences of excessive alcohol use; and,
- Drinking and driving, aggressive behaviour, intra-family violence, family breakdown and petty crime; Include a definition of 'a unit of alcohol'; Daily Alcohol Limits (DAL) – safe limits (that is, blood and breath limits) for driving.

**UNIT 2**  
**MODULE 3: APPLICATIONS OF BIOLOGY (cont'd)**

<b>SPECIFIC OBJECTIVES</b>	<b>EXPLANATORY NOTES</b>	<b>SUGGESTED PRACTICAL ACTIVITIES</b>
----------------------------	--------------------------	---------------------------------------

**Substance Abuse (cont'd)**

Students should be able to:

- |   |  |  |
|---|--|--|
| 4.5. describe the effects of the components of cigarette smoke on the respiratory and cardiovascular systems. | Passive smoking; effects of nicotine, tar and carbon monoxide on cilia, oxygen uptake, mucus secretion; development of hyperplasia, emphysema, chronic bronchitis, cancers including lung cancer; vasoconstriction, increase in number of erythrocytes, increase in blood viscosity, formation of blood clots. |  |
|---|--|--|

**Suggested Teaching and Learning Activities**

To facilitate students' attainment of the objectives of this Module, teachers are advised to engage students in teaching and learning activities listed below.

1. Encourage students to read and use current information in this particular area, since it is constantly changing.
2. Arrange visit to centres of excellence, such as a field station, hospital or research institute from which students can gain practical experience in these areas.
3. Allow students to view documentaries and make group presentations which deal with these issues.
4. Invite resource personnel to speak on concepts and issues discussed in this module.
5. Encourage involvement in school and/or community projects to assist in raising awareness of social and preventative medicine.
6. *Review and analyse current statistical data on HIV and AIDS in the Caribbean.*
7. *Review and analyse current statistical data on dengue in the Caribbean.*
8. *Model the transmission of a communicable or social disease by using a 'hands on' simulation.*

## UNIT 2

### MODULE 3: APPLICATIONS OF BIOLOGY (cont'd)

#### RESOURCES

Teachers and students may find reference to the following resource materials useful. The latest editions are recommended.

Durant, C.

*Biology for Cape Unit 2, A CXC® Study Guide.*  
Oxford University Press, 2014.

#### WEBSITES

UNAIDS (2016) 'The Prevention Gap Report'

[http://www.unaids.org/sites/default/files/media\\_asset/2016-prevention-gap-report\\_en.pdf](http://www.unaids.org/sites/default/files/media_asset/2016-prevention-gap-report_en.pdf)

UNAIDS (2014) 'The Gap Report'

[http://files.unaids.org/en/media/unaids/contentassets/documents/unaidspublication/2014/UNAIDS\\_Gap\\_report\\_en.pdf](http://files.unaids.org/en/media/unaids/contentassets/documents/unaidspublication/2014/UNAIDS_Gap_report_en.pdf)

UNAIDS (2016) 'AIDSinfo'

<http://aidsinfo.unaids.org/>

UNAIDS (2013) 'Global Report: UNAIDS Report on the global AIDS epidemic 2013'

[http://files.unaids.org/en/media/unaids/contentassets/documents/epidemiology/2013/gr2013/UNAIDS\\_Global\\_Report\\_2013\\_en.pdf](http://files.unaids.org/en/media/unaids/contentassets/documents/epidemiology/2013/gr2013/UNAIDS_Global_Report_2013_en.pdf)

Avrett, S (2012) 'Men Who Have Sex with Men and HIV in the Anglophone Caribbean: A Situation Review'. Arlington, VA: USAID's AIDS Support and Technical Assistance Resources, AIDSTAR-One, Task Order 1

[https://aidsfree.usaid.gov/sites/default/files/humanrights\\_msm.pdf](https://aidsfree.usaid.gov/sites/default/files/humanrights_msm.pdf)

[http://www.paho.org/hq/index.php?option=com\\_docman&task=doc\\_view&gid=23710&Itemid=270](http://www.paho.org/hq/index.php?option=com_docman&task=doc_view&gid=23710&Itemid=270)



## ◆ OUTLINE OF ASSESSMENT

### EXTERNAL ASSESSMENT (80%)

Paper 01 (1 hour 30 minutes)	Forty-five multiple-choice items, 15 from each Module.	40%
Paper 02 (2 hours 30 minutes)	Three compulsory structured essay questions, one from each Module. Each question is worth 30 marks.	40%
Paper 032 For private candidates only (2 hours)	Three questions, one from each Module, as follows: (a) a practical-based question to be executed by the candidate; (b) a question based on data analysis; (c) a data analysis/a planning and design exercise.	20%

### SCHOOL-BASED ASSESSMENT (20%)

The School-Based Assessment will consist of selected practical laboratory exercises and one research project in any Unit of any of the **CAPE®** Sciences (Biology, Chemistry or Physics).

#### MODERATION OF SCHOOL-BASED ASSESSMENT

The reliability (consistency) of the marks awarded by teachers on the School-Based Assessment is an important characteristic of high quality assessment. To assist in this process, the Council undertakes on-site moderation of the School-Based Assessment conducted by visiting external Moderators.

During Term 2/3, the Moderator will visit the centre. Teachers must make available to the Moderator **ALL** Assessment Sheets (Record of Marks), **ALL** lab books, Mark Schemes and the project or evidence of the project when marks have been transferred from another Unit/subject. **Teachers are NOT required to submit to CXC® samples of candidates' work, unless specifically requested to do so by the Council BUT will be required to submit the candidates' marks electronically.**

The Moderator will re-mark the skills and projects (if the marks for the projects are not transferred marks) for a sample of five candidates, who are selected using the following guidelines.

1. Candidates' total marks on the SBA are arranged in descending order (highest to lowest).
2. The sample comprises the work of the candidates scoring the:
  - (a) highest Total mark;
  - (b) middle Total mark;



- (c) lowest Total mark;
  - (d) mark midway between the highest and middle Total mark; and,
  - (e) mark midway between the middle and lowest Total mark.
3. *The moderator will re-mark the lab practical activities for the other skills (ORR, AI and PD) that are recorded in the five candidates' lab books as well as the research projects where applicable. Feedback will be provided by the Moderator to the teachers.*

*Where the total number of candidates is five or fewer, the Moderator will re-mark the skills for **ALL** the candidates.*

*The Moderator will submit the moderated marks (moderation of SBA Sample form), the moderation feedback report and the External Moderator report to the Local Registrar by 30 June of the year of the examination. Candidates' marks may be adjusted as a result of this exercise. A copy of the Assessment Sheets and all candidates' work must be retained by the school for three months after the examination results are published by CXC®.*

School-Based Assessment Record Sheets are available online via the CXC®'s website [www.cxc.org](http://www.cxc.org).

All School-Based Assessment Record of marks must be submitted online using the SBA data capture module of the Online Registration System (ORS).

## **ASSESSMENT DETAILS**

Each Unit of the syllabus is assessed as outlined below.

### **External Assessment by Written Papers (80% of Total Assessment)**

1. Paper 01 consists of 45 multiple-choice items. There will be a combined question paper and answer booklet for Paper 02.
2. S.I. Units will be used on all examination papers.
3. The use of silent, non-programmable calculators will be allowed in the examination. Candidates are responsible for providing their own calculators.
4. Data not specifically required to be recalled, defined or stated will be made available for this examination.

### **Paper 01 (1 hour 30 minutes – 40% of Total Assessment)**

#### **1. Composition of the Paper**

This paper will consist of 45 multiple-choice items, 15 from each Module. All questions are compulsory and knowledge of the entire Unit is expected. The paper will assess the candidate's knowledge across the breadth of the Unit.

2. **Mark Allocation**

The paper will be worth 45 marks, which will be weighted to 90 marks.

3. **Question Type**

Questions may be presented using diagrams, data, graphs, prose or other stimulus material.

**Paper 02 (2 hours 30 minutes – 40% of Total Assessment)**

1. **Composition of Paper**

This paper will consist of three questions, one from each module.

Questions on this paper test all three skills KC, UK and XS.

Knowledge of the entire Unit is expected.

2. **Mark Allocation**

The paper will be worth 90 marks, 30 marks per question *and distributed across the question sub-parts*.

3. **Question Type**

Questions will be presented in *structured essay format*. *The questions will test the skills of KC, UK and XS*. Answers are to be written in the question booklet.

**School-Based Assessment (20%)**

School-Based Assessment is an integral part of student assessment in the course covered by this syllabus. It is intended to assist students in acquiring certain knowledge, skills and attitudes that are associated with the subject. *Students are encouraged to work in groups*.

During the course of study for the subject, students obtain marks for the competence they develop and demonstrate in undertaking their School-Based Assessment assignments. These marks contribute to the final marks and grades that are awarded to students for their performance in the examination.

School-Based Assessment provides an opportunity to individualise a part of the curriculum to meet the needs of students. It facilitates feedback to the student at various stages of the experience. This helps to build the self- confidence of students as they proceed with their studies. School-Based Assessment also facilitates the development of the critical skills and abilities emphasised by this **CAPE®** subject and enhances the validity of the examination on which candidate performance is reported. School-Based Assessment, therefore, makes a significant and unique contribution to both the development of relevant skills and the testing and rewarding of students for the development of those skills.

The Caribbean Examinations Council seeks to ensure that the School-Based Assessment scores that contribute to the overall scores of candidates are valid and reliable estimates of accomplishment. The



guidelines provided in this syllabus are intended to assist in doing so.

### **Award of Marks**

The following skills will be assessed through the laboratory practical activities:

1. Analysis and Interpretation.
2. Manipulation and Measurement.
3. Observation, Recording and Reporting.
4. Planning and Designing.
5. Drawing

The candidates are also required to do a research project in any one Unit of the **CAPE®** Sciences. In each Unit, a total of 9 marks are to be allocated for each skill, and 9 marks for the project, as indicated in the Table below.

**Table 1**  
**School Based Assessment Skills**

<b>Skill</b>	<b>Unit 1</b>	<b>Unit 2</b>
Observation, Recording and Reporting	9	9
Manipulation and Measurement	9	-
Analysis and Interpretation	9	9
Planning and Designing	-	9
Drawing	9	9
Project*	9	9
<b>TOTAL</b>	<b>45 marks</b>	<b>45 marks</b>

**Teachers are required to provide criteria which clearly indicate how they award marks.**

*\*Please note that candidates will be required to do **one** research project in any Unit of any of the **CAPE®** Sciences (Biology, Chemistry or Physics) in the first sitting, and can use that mark for the other Units of the Sciences. So for example, a candidate may do a project in Unit 2 Physics in the first sitting, get a mark out of 9 and then (transfer) use that mark for Unit 1 Physics, Units 1 and 2 Chemistry and Units 1 and 2 Biology. Group work is allowed and encouraged.*

Each Module will carry a maximum of 15 marks.

Each candidate's total School-Based Assessment mark for any Unit should be divided in three and allocated to each Module equally.

Fractional marks should not be awarded. Wherever the Unit mark is not divisible by three, then

- (a) when the remainder mark is 1, it should be allocated to Module 1; and,
- (b) when the remainder is 2, one of the marks should be allocated to Module 2 and the other mark to Module 3.

Appropriate practical exercises for assessing any skill may be selected from any Module in the relevant Unit.

## **RESEARCH PROJECT**

### Objectives of the Research Project

*The research project will allow students to:*

1. *appreciate the use of the scientific method for discovery of new knowledge and to the solution of problems.*
2. *communicate accurately and effectively the purpose and results of research.*
3. *analyse relevant literature.*
4. *apply experimental skills and theory to the solution of problems.*
5. *synthesise information based on data collected.*
  - (a) *The research project should focus on at least one specific objective in the Unit. It can be from one or more modules within the Unit.*
  - (b) *The project must not exceed 1,500 words. The word count does not include: Tables, References, Table of contents, Appendices and Figures. Two marks will be deducted for exceeding the word limit by 200 words.*
  - (c) *Collaborative work is encouraged. Where collaborative work is done, group sizes must not exceed six (6) persons per group. The teacher is expected to use the group mark for the project and add it to the marks for the other skills for each individual candidate within the group.*
  - (d) *The report should be typewritten and double-spaced using 12pt font and should contain the following:*
    - (i) *Statement of Problem.*
    - (ii) *Rationale.*
    - (iii) *Research questions/Hypotheses.*
    - (iv) *Review of Literature.*
    - (v) *Methodology (paragraph format).*
    - (vi) *Presentation of Data collected from Research.*
    - (vii) *Discussion of findings.*

- (viii) Recommendations.
- (ix) Conclusion.
- (x) Bibliography (Referencing style from Communication Studies).

**CRITERIA FOR MARKING THE RESEARCH PROJECT**

1.	<i>Statement of Problem</i>		(2)
	<ul style="list-style-type: none"> <li>• <i>Problem identified and clearly stated (Problem identified but not clearly stated)</i></li> </ul>	2 (1)	
2.	<i>Rationale/Statements of Purpose of Investigation</i>		(1)
	<ul style="list-style-type: none"> <li>• <i>Clearly states reason for project, for example, the benefits (Justifies solutions for the problem)</i></li> </ul>	1	
3.	<i>Research Questions/ Hypotheses</i>		(3)
	<ul style="list-style-type: none"> <li>• <i>Clearly stated research questions/hypotheses (no more than two)</i></li> <li>• <i>Testable</i></li> <li>• <i>Variables clearly stated</i></li> </ul>	1 1 1	
4.	<i>Critical review of literature (Analysis and evaluation of appropriate literature)</i>		(7)
	<ul style="list-style-type: none"> <li>• <i>In text citation using consistent format</i></li> <li>• <i>At least four sources cited</i></li> <li>• <i>Credible and relevant sources (scholarly articles) cited</i></li> <li>• <i>Analysis of information from sources, for example, Who, what...</i> <ul style="list-style-type: none"> <li>- <i>Comparison of information from sources cited</i></li> <li>- <i>Accurate analysis of information from sources</i></li> <li>- <i>Final synopsis of the literature</i></li> <li>- <i>Personal reflection in relation to the area researched</i></li> </ul> </li> </ul>	1 1 1 1 1 1 1	
5.	<i>Methodology</i>		(3)
	<p><u><i>For Non-Experimental Research only</i></u></p> <ul style="list-style-type: none"> <li>• <i>Clearly outlines method(s) of collecting data (Method only stated)</i></li> <li>• <i>Methods chosen supported by literature review OR alternative method justified</i></li> </ul> <p><u><i>For Experimental Research only</i></u></p> <ul style="list-style-type: none"> <li>• <i>Clearly describes method used</i></li> <li>• <i>Repetition</i></li> <li>• <i>Appropriate use of apparatus and materials</i></li> </ul>	2 (1) 1  1 1 1	
6.	<i>Presentation of data collected from research</i>		(3)

	<ul style="list-style-type: none"> <li>• <i>Appropriate format for presentation of data</i></li> <li>• <i>Use of tables, graphs/figures</i></li> <li>• <i>Properly annotated (Titles of tables at top; titles of figures at bottom of figure; Biological illustrations labelled...)</i></li> </ul>	1 1 1	
7.	<i>Discussion of Findings</i>		(8)
	(a) <i>Analysis of Data</i>		
	<ul style="list-style-type: none"> <li>• <i>Accurate identification of trends/relationships</i></li> <li>• <i>Indicate differences in trends/relationships</i></li> </ul>	1 1	
	(b) <i>Interpretation of Findings</i>		
	<ul style="list-style-type: none"> <li>• <i>Discussion of results in terms of literature reviewed</i></li> <li>• <i>Clearly points toward answering of research questions (points toward answering of research questions but somewhat unclear)</i></li> <li>• <i>Supported by the data presented</i></li> <li>• <i>At least TWO limitations of the research conducted (ONE limitation stated)</i></li> </ul>	1 2 (1) 1 2 (1)	
8.	<i>Recommendations</i>		(2)
	<ul style="list-style-type: none"> <li>• <i>At least two recommendations based on and supported by findings (One recommendation based on and supported by findings)</i> <i>Award zero if recommendations are not related to purpose or supported by findings</i></li> </ul>	2 (1)	
9.	<i>Conclusion</i>		(2)
	<ul style="list-style-type: none"> <li>• <i>Conclusion clear and based on findings</i></li> <li>• <i>Conclusion relates to the purpose of the project</i></li> </ul>	1 1	
10.	<i>Communication of information</i>		(3)
	<ul style="list-style-type: none"> <li>• <i>Few grammatical errors or flaws and good use of appropriate technical terms</i></li> <li>• <i>(Several grammatical errors or flaws and poor use of appropriate technical terms)</i></li> <li>• <i>Information communicated in a logical manner</i></li> </ul>	2 (1) 1	
11.	<i>Bibliography</i>		(2)
	<ul style="list-style-type: none"> <li>• <i>At least four cited sources referenced</i></li> <li>• <i>Written using a consistent referencing style</i></li> </ul>	1 1	
12.	<i>Exceeding the word limit by more than 200 words</i>		(-2)
<b>Total</b>			<b>36</b>

## SCHOOL-BASED ASSESSMENT – GENERAL GUIDELINES FOR TEACHERS

1. Each candidate is required to keep a laboratory workbook which is to be marked by the teacher. Teachers are also expected to assess candidates as they perform practical exercises in which Manipulation and Measurement skills are required.
2. A maximum of two skills may be assessed by any one experiment.
3. The maximum mark for any skill will be 9. The mark *awarded* for each skill assessed by practical exercises should be the average of at LEAST TWO separate assessments *for MM, AI and PD*. *Only one mark is required for ORR*. In each Unit, total marks awarded at the end of each Module will be 0 to 15.
4. Candidates who do not fulfil the requirements for the School-Based Assessment will be considered absent from the whole examination.
5. Candidates' laboratory books should contain all practical work undertaken during the course of study. Those exercises which are selected for use for the School-Based Assessment should be clearly identified. The skill(s) tested in these selected practical exercises, the marks assigned and the scale used must be placed next to the relevant exercises.
6. Teachers' criteria and breakdown of marks for assessing a skill must be clearly stated and submitted with the laboratory books.
7. The standard of marking should be consistent.
8. The relationship between the marks in the laboratory books and those submitted to **CXC®** in the ORS should be clearly shown.

## ◆ REGULATIONS FOR PRIVATE CANDIDATES

1. Candidates who are registered privately will be required to sit Papers 01, 02 and 032. Detailed information on Papers 01, 02 and 032 is given on page 49 of this syllabus.
2. Paper 032 will constitute *20 per cent* of the overall assessment of the candidates' performance on the Unit.

## ◆ REGULATIONS FOR RESIT CANDIDATES

1. *Candidates may reuse any moderated SBA score within a two-year period. In order to assist candidates in making decisions about whether or not to reuse a moderated SBA score, the Council will continue to indicate on the preliminary results if a candidate's moderated SBA score is less than 50 per cent in a particular Unit.*
2. *Candidates re-using SBA scores should register as "Re-sit candidates" and must provide the previous candidate number when registering.*

3. *Resit candidates must complete Papers 01 and 02 of the examination for the year in which they register.*

## ◆ ASSESSMENT GRID

The Assessment Grid for each Unit contains marks assigned to papers and to Modules and percentage contribution of each paper to total scores.

<i>Paper</i>	<i>Module 1</i>	<i>Module 2</i>	<i>Module 3</i>	<i>Paper Total (Weighted Total)</i>	<i>% Weighting of Papers</i>
<i>Paper 01</i>	15 (30)	15 (30)	15 (30)	45 (90)	40
<i>Paper 02</i>	30	30	30	90	40
<i>Paper 031/2</i>	15	15	15	45	20
<i>Module Totals</i>	60	60	60	180 (225)	100
<i>Weighted Module</i>	75	75	75	225	100

## ◆ RESOURCES

The following is a list of books and other printed material that might be used for CAPE Biology. The list is by no means exhaustive. Each student should have access to at least one text.

### Texts

Clegg, C.J. and Mackean, D.J.      *Advanced Biology – Principles and Applications*. London: John Murray, 2000.

### Supplementary Texts and Teachers' Guide

Anon      *Preliminary Biology Study Guide*. University of the West Indies, Barbados: Distance Education Centre, 1997.

Bradfield, P.      *AS & A2 Level Biology*. Essex: Pearson Educational, 2001.

Cadogan, A. and Best, G.      *Environment and Ecology: Biology Advanced Studies*. Glasgow and London: Nelson Blackie, 1992.

Chapman, J. L. and Reiss, M.      *Ecology*. Cambridge: Cambridge University Press, 1992.

Huxley, A.      *Green Inheritance*. London: Gaia Books, 1992.

Fosbery, R., Jones, M. and Taylor, D.      *Advanced Biology, Volume 1 and 2*. Cambridge: Cambridge University Press, 2002.

Jones, M., Fosbery, R. et al      *AS Level and A Level Biology*. Cambridge: Cambridge University Press, 2003.

Kent, M.      *Advanced Biology*. Oxford: Oxford Press, 2000.

Margulis, L. and Schwartz, K.      *Five Kingdoms*. New York: W.H. Freeman and Company, 1998.

Odlum, E.P.      *Ecology: A Bridge Between Science and Society*. Sunderland, USA: Sinauer Associates, 1997.

Raven, P., Johnson, G., Singer, S., et al      *Biology, 7th Edition*. Boston, MA: McGraw Hill, 2005.

Toole, G. and Toole, S.      *New Understanding of Biology for Advanced Level*. Cheltenham: Stanley Thornes Publishers Limited, 1997.

## Reference Books for Field Study

### Plant Identification

- Barlow, V. *The Nature of the Islands*. Dunedin, Florida: Cruising Guide Publications, 1998.
- Fournet, J. and Hammerton, J. *Weeds of the Lesser Antilles and or Mauvaises herbes des petites Antilles*. INRA, Paris/CARDI, 1994.
- Nellis, D. *Seashore Plants of South Florida and the Caribbean*. Sarasota: Pineapple Press, 1994.
- Whittaker, M. *Medicinal Plants of St Kitts and Nevis Part 1*. Basseterre, St. Kitts: College of Further Education, 1992.

### Animal Identification

- Raffaele, H.A., Wiley, J., Garrido, O., Keith, A. and Raffaele, J. *A Guide to Birds of the West Indies*. New Jersey: Princeton University Press, 2003.
- Stirling, P. *Butterflies and Other Insects of the Eastern Caribbean*. London: Macmillan Caribbean, 1986.
- Stokes, F. *Divers and Snorkeler's Guide to the Fishes and the Sea Life of the Caribbean*. Florida, Bahamas and Bermuda, Philadelphia: Academy of Natural Sciences of Philadelphia, 1984.
- Sultry, L. *Seashell Treasures of the Caribbean*. London: Macmillan Caribbean, 1986.
- Sutty, L. *Fauna of the Caribbean – Last Survivors*. London: Macmillan Press, 1993.





## ◆ GLOSSARY OF EXAMINATION TERMS

### KEY TO ABBREVIATIONS

KC - Knowledge and Comprehension

UK - Use of Knowledge

XS - Experimental Skills

WORD	DEFINITION	NOTES
<b>Analyse</b>	Examine in detail	UK
<b>Annotate</b>	Add a brief note to a label	Simple phrase or a few words only, KC
<b>Apply</b>	Use knowledge and or principles to solve problems	UK
<b>Assess</b>	Present reasons for the importance of particular structures, relationships or processes	UK
<b>Calculate</b>	Arrive at the solution to a numerical problem	KC/UK
<b>Cite</b>	Provide a quotation or reference to the subject	KC
<b>Classify</b>	Divide into groups according to observable characteristics	UK
<b>Comment</b>	State opinion or view with supporting reasons	UK
<b>Compare</b>	State similarities and differences	An example of a significance of each similarity and the difference stated may be required for comparisons which are other than structural, UK
<b>Construct</b>	Use a specific format to make and or draw a graph, histogram, pie chart or other representations using data or material provided or drawn from practical investigations; build (for example, a model), draw scale diagram	Such representations should normally bear a title, appropriate headings and legend; UK

<b>WORD</b>	<b>DEFINITION</b>	<b>NOTES</b>
<b>Deduce</b>	Make a logical connection between two or more pieces of information; use data to arrive at a conclusion	UK
<b>Define</b>	State concisely the meaning of a word or term	This should include the defining equation and or formula where relevant; KC
<b>Demonstrate</b>	Show; direct attention to ...	KC
<b>Describe</b>	Provide detailed factual information of the appearance or arrangement of a specific structure or sequence of a specific process	Description may be words, drawings or diagrams or an appropriate combination. Drawings or diagrams should be annotated to show appropriate detail where necessary; KC
<b>Design</b>	Include planning and presentation with appropriate practical detail	UK/XS
<b>Determine</b>	Find the value present with appropriate practical detail	Where hypotheses are stated or when tests are to be conducted, possible outcomes should be clearly shown and/or the way in which data will be analysed and presented; UK/XS
<b>Develop</b>	Expand or elaborate an idea or argument with supporting reasons	KC/UK
<b>Diagram</b>	Simplified representation showing the relationship between components	KC/UK
<b>Differentiate or Distinguish</b>	State or explain briefly those differences between or among items which can be used to define the items or place them into separate categories	KC/UK

<b>WORD</b>	<b>DEFINITION</b>	<b>NOTES</b>
<b>Discuss</b>	Present reasoned argument; consider points both for and against; explain the relative merits of a case	UK
<b>Draw</b>	Make a line representation from specimens or apparatus which shows an accurate relation between the parts	In case of drawings from the specimens, the magnification must always be stated; KC/UK/XS
<b>Estimate</b>	Make an approximate quantitative judgement	UK
<b>Evaluate</b>	Weigh evidence and make judgements based on given criteria	The use of logical supporting reasons for a particular point is more important than view held; usually both sides of an argument should be considered ; UK
<b>Explain</b>	Give reasons based on recall; account for	KC/UK
<b>Find</b>	Locate a feature or obtain as from a graph	UK
<b>Identify</b>	Name specific components or features	KC
<b>Illustrate</b>	Demonstrate clearly using appropriate examples or diagrams	KC
<b>Interpret</b>	Explain the meaning of	UK
<b>Formulate</b>	Devise hypotheses	UK
<b>Label</b>	Add names to identify structures or parts indicated by pointers	KC/XS
<b>List</b>	Itemise without detail	KC
<b>Measure</b>	Take accurate quantitative readings using appropriate instruments	XS

<b>WORD</b>	<b>DEFINITION</b>	<b>NOTES</b>
<b>Name</b>	Give only the name of	No additional information is required; KC
<b>Note</b>	Record observation	XS
<b>Observe</b>	Pay attention to details which characterise a specimen, reaction or change taking place; to examine and note scientifically	Observation may involve all the senses and/or extensions of them but would normally exclude the sense of taste; XS
<b>Outline</b>	Give basic steps only	XS
<b>Plan</b>	Prepare to conduct an exercise	XS
<b>Predict</b>	Use information provided to arrive at a likely conclusion or suggest a possible outcome	UK
<b>Record</b>	Write an accurate description of the full range of observations made during a given procedure	This includes the values for any variable being investigated; where appropriate, record; data may be depicted in graphs, histograms or tables; XS
<b>Relate</b>	Show connections between; explain how one set of facts or data depends on others or are determined by them	UK
<b>Sketch</b>	Make a simple freehand diagram showing relevant proportions and any important details	KC/UK/XS
<b>State</b>	Provide factual information in concise terms outlining explanations	KC
<b>Suggest</b>	Offer an explanation deduced from information provided or previous knowledge (... a hypothesis; provides a generalisation which offers a likely explanation for a set of data or observations.)	No correct or incorrect solution is presumed but suggestions must be acceptable within the limits of scientific knowledge; UK

WORD	DEFINITION	NOTES
Test	To find out, following set procedures	XS
Use	Implies the need to recall and apply in order to come to a conclusion	UK

**Western Zone Office**  
**28 September 2017**



# CARIBBEAN EXAMINATIONS COUNCIL

Caribbean Advanced Proficiency Examination®  
CAPE®



## BIOLOGY

### Specimen Papers and Mark Schemes/Keys

**Specimen Paper:** - Unit 1 Paper 01  
Unit 1 Paper 02  
Unit 1 Paper 032  
Unit 2 Paper 01  
Unit 2 Paper 02  
Unit 2 Paper 032

**Mark Scheme and Key:** - Unit 1 Paper 01  
Unit 1 Paper 02  
Unit 1 Paper 032  
Unit 2 Paper 01  
Unit 2 Paper 02  
Unit 2 Paper 032

**CARIBBEAN EXAMINATIONS COUNCIL**

**CARIBBEAN ADVANCED PROFICIENCY EXAMINATION**

**BIOLOGY**

**SPECIMEN 2017**

**TABLE OF SPECIFICATIONS**

**Unit 1 – Paper 02**

Module	Question	Specific Objective	Content	Cognitive Level Marks			Total
				KC	UK	XS	
1	1	1.9, 1.2, 4.4, 1.10, 1.11, 2.2, 2.3, 2.1, 3.1, 3.2	Food tests; Enzyme activity; Structure and function of prokaryotic and eukaryotic cells	10	15	5	30
2	2	2.6, 4.1, 4.2, 4.4, 5.4, 5.4	Meiosis I; R-DNA to produce insulin; Isolating mechanisms	10	15	5	30
3	3	2.2, 2.6, 2.3, 2.7	Hormones; Fertilization; Contraception	10	15	5	30
<b>Total</b>				<b>30</b>	<b>45</b>	<b>15</b>	<b>90</b>

**Unit 1 – Paper 032 (Alternative to SBA)**

Module	Question	Specific Objective	Content	Cognitive Level Marks			Total
				KC	UK	XS	
1	1	Practical	Module 1	0	5	10	15
2	2	Data Analysis	Module 1	0	5	10	15
3	3	Planning & Design	Module 2	0	-	15	15
<b>Total</b>				<b>0</b>	<b>10</b>	<b>35</b>	<b>45</b>

**CARIBBEAN EXAMINATIONS COUNCIL**

**CARIBBEAN ADVANCED PROFICIENCY EXAMINATION**

**BIOLOGY**

**SPECIMEN 2017**

**TABLE OF SPECIFICATIONS**

**Unit 2 – Paper 02**

Module	Question	Specific Objective	Content	Cognitive Level Marks			Total
				KC	UK	XS	
1	1	1.4, 3.1, 3.3, 3.4, 4.3, 4.5	Drawing and interpreting a graph; N <sub>2</sub> cycle; Conservation of forests	10	15	5	30
2	2	2.1, 2.3, 3.1, 3.3	Detailed drawing of a cell; Translocation; Transport in humans	10	15	5	15
3	3	3.3, 2.1, 2.2, 2.4, 2.5, 2.9, 2.10	VO <sub>2</sub> MAX; Immune system; Vaccination	10	15	5	30
<b>Total</b>				<b>30</b>	<b>45</b>	<b>15</b>	<b>90</b>

**Unit 2 – Paper 032**

**Alternative to SBA**

Module	Question	Specific Objective	Content	Cognitive Level Marks			Total
				KC	UK	XS	
1	1	Practical	Module 2	0	5	10	15
2	2	Data Analysis	Module 1	0	-	15	15
3	3	Planning & Design	Module 3	0	5	10	15
<b>Total</b>				<b>0</b>	<b>10</b>	<b>35</b>	<b>45</b>





**CANDIDATE – PLEASE NOTE!**

PRINT your name below and return this booklet with your answer sheet. Failure to do so may result in disqualification.

TEST CODE **02107010**

**SPEC 2017/02107010**

**CARIBBEAN EXAMINATIONS COUNCIL  
CARIBBEAN ADVANCED PROFICIENCY EXAMINATION®**

**SPECIMEN PAPER  
MULTIPLE CHOICE QUESTIONS  
FOR**

**BIOLOGY**

**UNIT 1 – Paper 01**

**READ THE FOLLOWING INSTRUCTIONS CAREFULLY.**

1. This test consists of 45 items. You will have 1 hour and 30 minutes to answer them.
2. In addition to this test booklet, you should have an answer sheet.
3. Do not be concerned that the answer sheet provides spaces for more answers than there are items in this test.
4. Each item in this test has four suggested answers lettered (A), (B), (C), (D). Read each item you are about to answer and decide which choice is best.
5. On your answer sheet, find the number which corresponds to your item and shade the space having the same letter as the answer you have chosen. Look at the sample item below.

Sample Item

Which of the following metal atoms is present in a haemoglobin molecule?

- (A) Iron
- (B) Copper
- (C) Calcium
- (D) Magnesium

Sample Answer



The correct answer to this item is “Iron”, so (A) has been shaded.

6. If you want to change your answer, erase it completely before you fill in your new choice.
7. When you are told to begin, turn the page and work as quickly and as carefully as you can. If you cannot answer an item, go on to the next one. You may return to that item later.
8. You may do any rough work in this booklet.
9. Figures are not necessarily drawn to scale.
10. The use of non-programmable calculators is allowed.

**DO NOT TURN THIS PAGE UNTIL YOU ARE TOLD TO DO SO.**

---

Copyright © 2017 Caribbean Examinations Council.  
All rights reserved.

1. Water provides a constant external environment for many aquatic organisms. The specific property of water which allows for this is its
- (A) high heat capacity
  - (B) high heat of vaporisation
  - (C) high surface tension
  - (D) high heat of fusion

Item 2 refers to the diagram below.

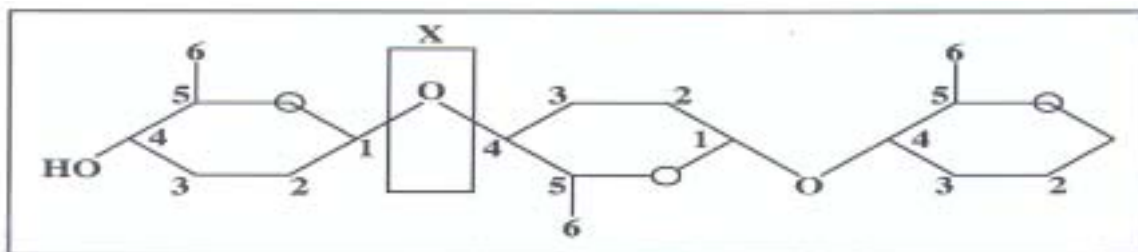

2. The 3-unit molecular structure shown above is found in which of the following polymers?
- (A) Glycogen
  - (B) Cellulose
  - (C) Starch
  - (D) Collagen

3. Which of the following numbers represent the correct number of fatty acid residues normally present in a phospholipid molecule?

- (A) 1
- (B) 2
- (C) 3
- (D) 4

Item 4 refers to the amino acid alanine which has the following molecular formula.

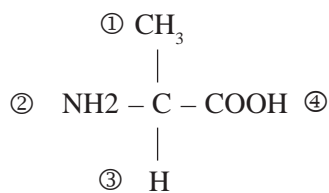

4. Which of the following functional groups must combine to form a peptide bond?
- (A) 1 and 2
  - (B) 3 and 4
  - (C) 2 and 4
  - (D) 2 and 3

5. Which of the following types of bonds is responsible for stabilizing the secondary structure of a protein?

- (A) Disulphide
- (B) Hydrophobic
- (C) Ionic
- (D) Hydrogen

6. Which of the following molecules shows the characteristics listed below?

- I. The triple helices are linked by covalent cross links.
- II. They are polypeptides in the form of three helices.
- III. Every third amino acid in each helix is glycine.

- (A) Collagen
- (B) Glycogen
- (C) Haemoglobin
- (D) Glycoprotein

Item 7 refers to the diagram below which shows the ultrastructure of a eukaryotic cell.

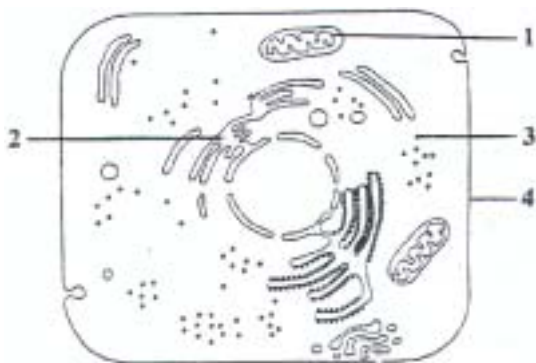

7. Which of the following cell structures, labelled 1, 2, 3 and 4, is involved in the synthesis of lipids and steroids?

- (A) 1
- (B) 4
- (C) 2
- (D) 3

Item 8 refers to the following structures found in cells.

- I. Cell wall
- II. Cell Membrane
- III. Centrioles
- IV. Golgi Apparatus

8. Which of the following combinations are features common to BOTH plant and animal cells?

- (A) I and II
- (B) II and IV
- (C) II, III and IV
- (D) II and III

9. All of the following characteristics are typical of prokaryotes EXCEPT

- (A) they contain both ribosomes and a nucleus
- (B) their average diameter ranges between 0.5 - 10  $\mu\text{m}$
- (C) they have circular DNA
- (D) they are mainly unicellular

10. Xylem can MOST accurately be described as a tissue because it

- (A) consists of more than one type of cell
- (B) consists of vessels conducting mainly water and mineral salts
- (C) is impregnated with lignin
- (D) provides mechanical support for plants

GO ON TO THE NEXT PAGE

Item 11 refers to the figure below which shows part of the cell-surface membrane of a red blood cell.



11. Molecule Z acts as a carrier to transport selected substances across the membrane. Which of the following substances is MOST readily transported by this carrier molecule?

- (A) Fructose
- (B) Water
- (C) Glucose
- (D) Carbon-dioxide

12.  $\text{Na}^+$  and  $\text{K}^+$  cannot pass freely into a cell across the phospholipid bilayer because

- (A) they are repelled by the charged cytoplasm
- (B) they are too large to pass
- (C) of the hydrophobic nature of the layer
- (D) they are moving against a concentration gradient

13. Amylase found in germinating seeds is incubated with starch at  $25^\circ\text{C}$  and pH 2. When a sample is removed after five minutes and mixed with a solution of iodine in potassium iodide solution, the mixture turns to a blue-black colour. The MOST likely explanation for this observation is

- (A) all the starch has been hydrolysed to maltose
- (B) a specific inhibitor of the amylase is present
- (C) amylase does not catalyse the hydrolysis of starch at  $25^\circ\text{C}$
- (D) the pH is too low for the reaction to proceed quickly

Item 14 refers to the graph below which shows the rate of an enzyme catalysed reaction with and without inhibitors.

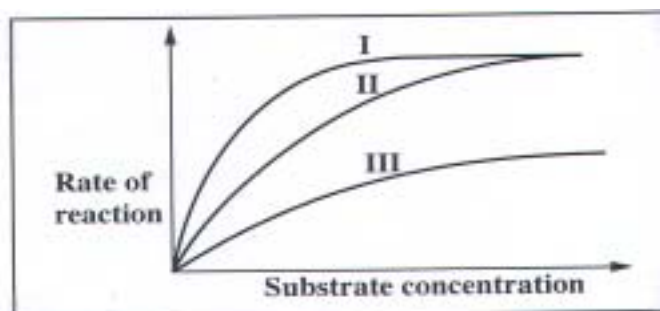

14. Which of the following sequences describes the types of reaction shown by Graphs I, II and III?

- |     | <b>Graph I</b>        | <b>Graph II</b>           | <b>Graph III</b>          |
|-----|-----------------------|---------------------------|---------------------------|
| (A) | Competitive inhibitor | Non-competitive inhibitor | No inhibitor              |
| (B) | Competitive inhibitor | No inhibitor              | Non-competitive inhibitor |
| (C) | No inhibitor          | Competitive inhibitor     | Non-competitive inhibitor |
| (D) | No inhibitor          | Non-competitive inhibitor | Competitive inhibitor     |

GO ON TO THE NEXT PAGE

15. Which of the following graphs BEST illustrates the effect of temperature on an enzyme controlled reaction?

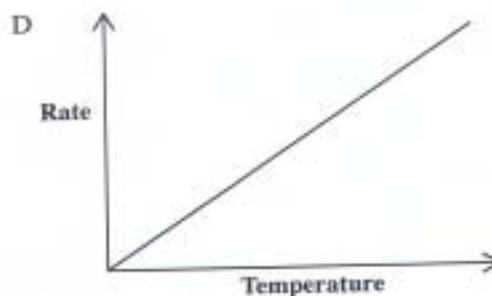
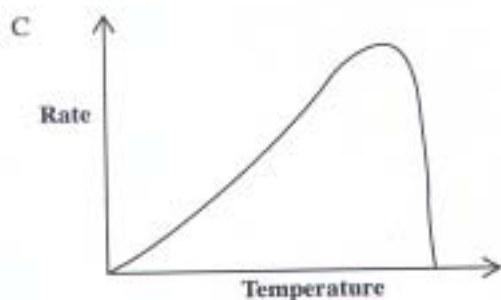
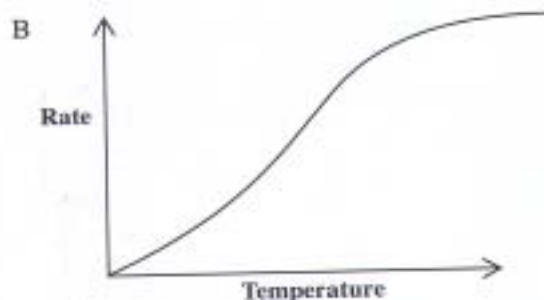
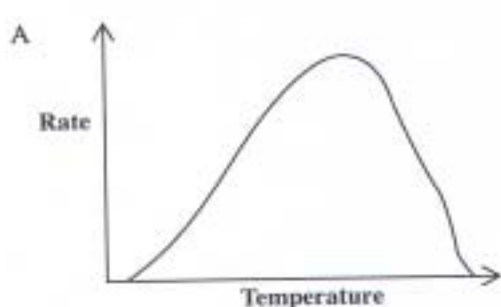

---

Item 16 refers to the following diagram.

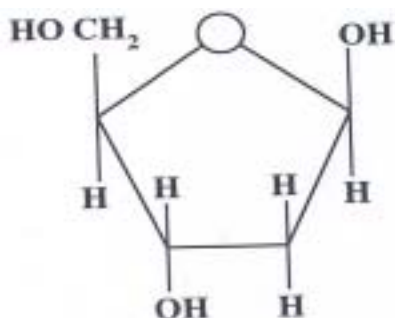

16. Which of the following molecules contains the monosaccharide shown above?

- (A) Glycogen
- (B) RNA
- (C) Cellulose
- (D) DNA

17. Which of the following molecules are required to activate amino acids for attachment during translation in protein synthesis?

- (A) tRNA and ATP
- (B) mRNA and ATP
- (C) mRNA, rRNA and ATP
- (D) tRNA, mRNA, rRNA and ATP

18. The MAXIMUM number of amino acid molecules which can be coded for by the triplet code is

- (A) 3
- (B) 20
- (C) 60
- (D) 64

19. Which of the following statements is true of homologous chromosomes?

- (A) They consist of two identical chromatids.
- (B) They move to the same pole during nuclear division.
- (C) They have the same sequence of genes.
- (D) They have the same sequence of bases.

---

Item 20 refers to diagrams which show the stages in the first division of meiosis.



20. Which of the following sequences represents the correct sequence of events?

- (A) 3 2 4 1 5
- (B) 5 2 4 1 3
- (C) 3 2 1 4 5
- (D) 2 3 4 1 5

GO ON TO THE NEXT PAGE

Item 21 refers to the following animal cell during meiosis II.

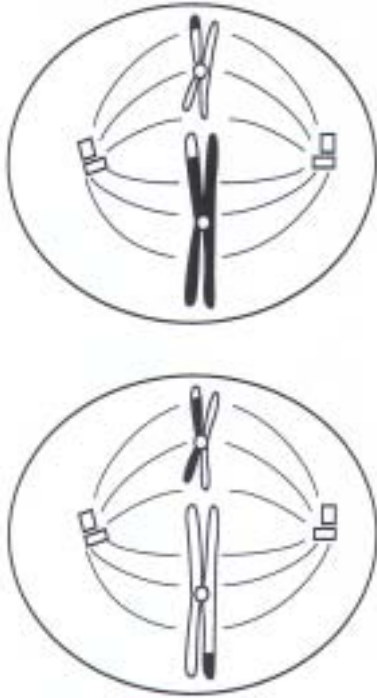

21. Which of the following stages of meiosis II is shown in the diagram above?

- (A) Prophase
- (B) Metaphase
- (C) Anaphase
- (D) Telophase

22. Which of the following features correctly describe advantages of asexual reproduction to a species?

- I. Only one parent is required
- II. Self pollination is not dependent on wind or insects
- III. Rapid multiplication of the species
- IV. The offspring are genetically identical

- (A) I and IV
- (B) I, III and IV
- (C) I, II and IV
- (D) I, II, III and IV

23. In flowering plants, meiosis occurs in the

- (A) embryo sacs
- (B) ovules
- (C) pollen mother cells
- (D) ovary walls

Item 24 refers to the diagram below showing a fertilised ovule and carpel.

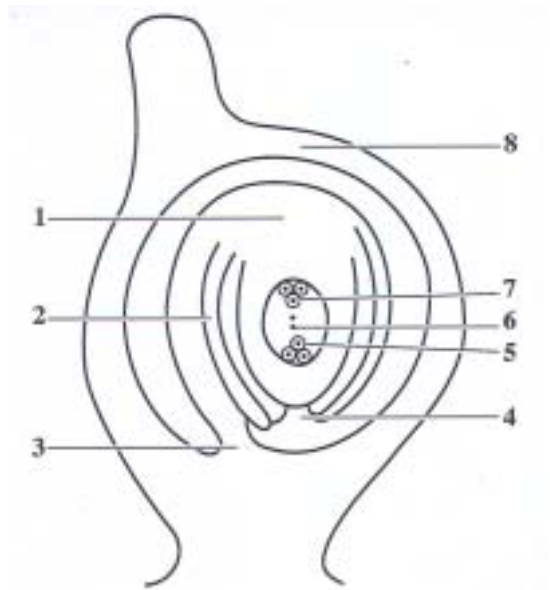

24. Which of the following represents the structures which will become the

- I. embryo
- II. testa
- III. micropyle of the seed

	I	II	III
(A)	6	2	3
(B)	7	8	1
(C)	6	1	7
(D)	5	2	4

Item 25 refers to the diagram below which shows a germinating pollen grain and a mature ovule.

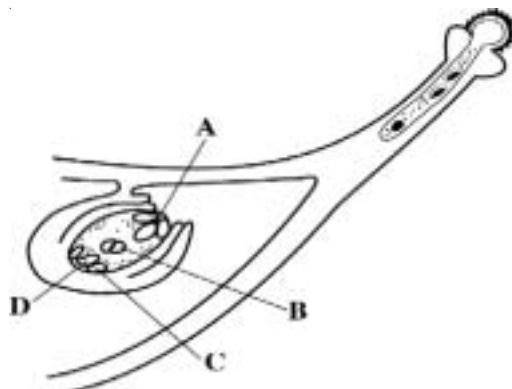

25. The nucleus which fuses with the male nucleus to form the zygote is

- (A) A
- (B) B
- (C) C
- (D) D

Item 26 refers to the following stages in the development of human sperm.

- I. Spermatid
- II. Spermatogonium
- III. Primary Spermatocyte

26. Which of the following combinations is the correct order of sperm formation?

- (A) I, II, III
- (B) II, III, I
- (C) II, I, III
- (D) I, III, II

27. The function of interstitial cells (cells of Leydig) is the production of

- (A) oestrogen
- (B) progesterone
- (C) follicle stimulating hormone
- (D) testosterone

Item 28 refers to the diagram below which shows the levels of various hormones involved in the menstrual cycle in human females.

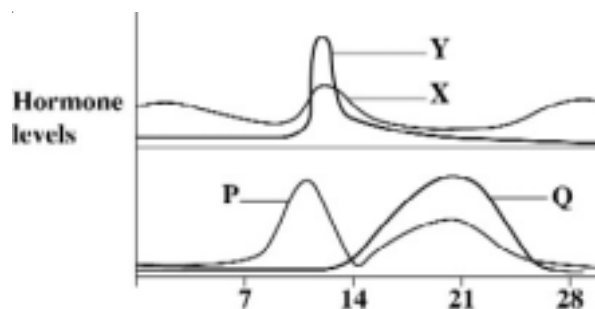

28. Which ONE of the following is the most accurate deduction that can be made from the diagram?

- (A) Q at high concentrations stimulates Y.
- (B) P at high concentrations stimulates Y.
- (C) P at low concentrations stimulates X.
- (D) Q at low concentrations inhibits X.

29. The MAIN function of the placenta in humans is that it

- (A) protects the embryo
- (B) separates foetal and maternal blood
- (C) allows exchange of materials between foetus and mother
- (D) supports the embryo

30. All of the following are able to cross the placenta EXCEPT

- (A) *E. coli* bacterium
- (B) Human Immuno-Deficiency Virus
- (C) carbon monoxide
- (D) alcohol

GO ON TO THE NEXT PAGE



In tomatoes: R - red fruit (dominant)  
r - yellow fruit  
T - tall plant (dominant)  
t - short plant

Both genes are on different chromosomes.

31. A tomato plant homozygous for allele R reproduces. The number of copies of this allele which will be found in the male gamete of this plant is

- (A) 1
- (B) 2
- (C) 4
- (D) 8

32. The characteristic of inflated pea pods is controlled by one allele of a particular gene. The other allele results in constricted pods.

Half the pollen grains of a heterozygous pea plant show the characteristic of inflated pods because alleles separate at meiosis during

- (A) anaphase I and anaphase II
- (B) metaphase II and anaphase II
- (C) prophase I and prophase II
- (D) metaphase I and anaphase I

33. A woman who is heterozygous for sickle cell anaemia, marries a man who is also heterozygous for sickle cell. The probability that their third child will carry a sickle cell allele is

- (A) 25%
- (B) 50%
- (C) 75%
- (D) 100%

34. The genotype of human zygotes will differ from that of both parents and grandparents.

Which of the following occurrences does NOT contribute to this variation?

- (A) Chiasmata occurring during meiosis
- (B) Mutation of genes
- (C) Presence of recessive genes
- (D) Random combination of gametes

35. The coding DNA triplet for glutamic acid is CTT. This mutates to CAT in sickle cell haemoglobin. The complementary mRNA codon for sickle cell anemia is

- (A) GAA
- (B) GTC
- (C) GTT
- (D) GUA

36. Which of the following chromosomal mutations, labelled I - IV, is correctly identified?

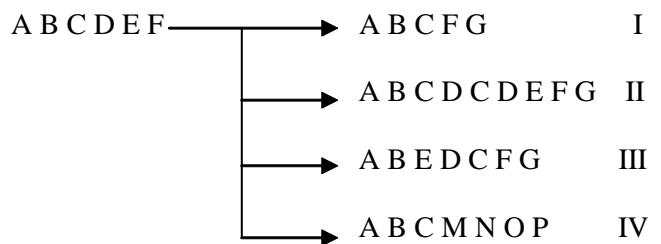

- (A) I - duplication
- (B) II - translocation
- (C) III - inversion
- (D) IV - deletion

37. In which of the following events is variation NOT involved?

- (A) Segregation of chromosomes at anaphase
- (B) Chiasma formation in chromosomes
- (C) Structural changes in chromosomes
- (D) Pairing of X and Y chromosomes

GO ON TO THE NEXT PAGE

38. In a population which displays wide variation in body mass, which of the following graphs BEST displays natural selection for this characteristic?

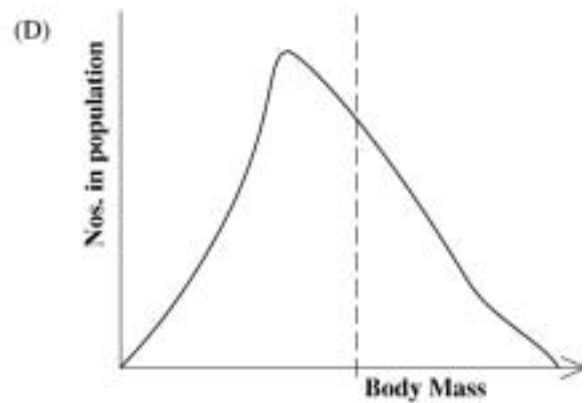
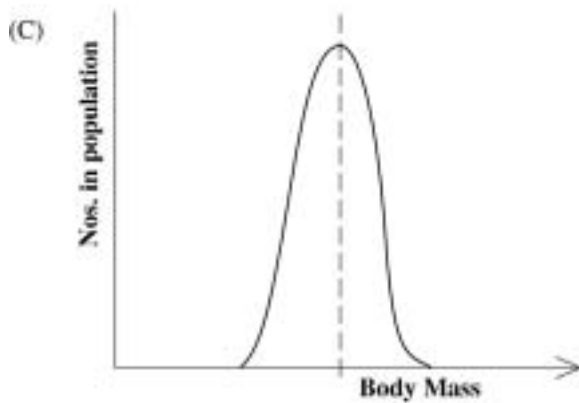
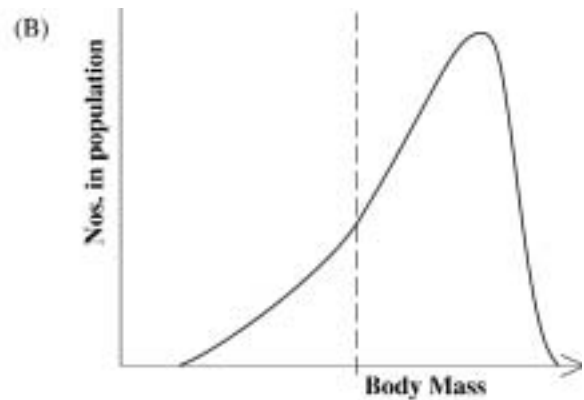
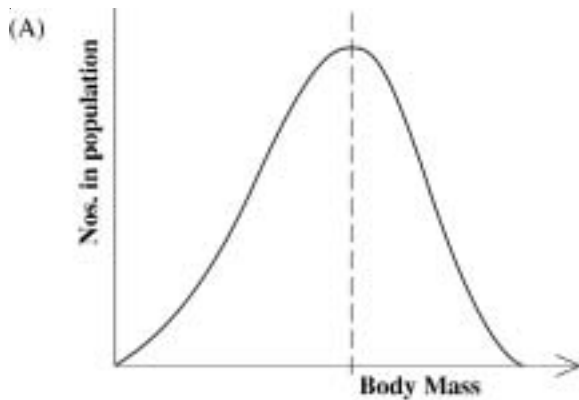

39. Which of the following BEST explains the type of natural selection exhibited by the peppered moths living in a polluted area?

- (A) Stabilizing selection
- (B) Selection pressure
- (C) Directional selection
- (D) Disruptive selection

40. Which of the following features can be BEST used to determine whether sexually reproducing flowering plants, from separate populations, are members of the same species?

- (A) They have the ability to cross-fertilize.
- (B) They have the ability to cross-pollinate.
- (C) They have the ability to produce viable seeds.
- (D) The viable seeds can produce fertile gametes.

41. Which of the following sequences illustrates the correct hierarchical order for the classification of living things?

- (A) Class, order, family, genus
- (B) Genus, order, class, family
- (C) Family, class, order, genus
- (D) Order, family, genus, class

Item 42 refers to the following classification scheme illustrating taxonomic levels.

Animalia  
  Chordata  
    Mammalia  
      Rodentia  
        Muroidea  
          *Rattus*  
            *rattus*

42. Which of the following is the correct name for the family to which this organism belongs?

- (A) Chordata
- (B) Mammalia
- (C) *Rattus*
- (D) Muroidea

43. When purebreeding white-seeded wheat plants were crossed with purebreeding red-skinned wheat plants, all of the F<sub>1</sub> generation had pink seeds.

The F<sub>1</sub> plants were self-pollinated producing plants with a phenotype ratio of

1 red seeded : 2 pink : 1 white seeded.

The number of genes controlling seed colour in this cross is

- (A) 2
- (B) 4
- (C) 1
- (D) 3

44. In which of the following taxonomic groups will all the organisms be MOST similar to each other?

- (A) Family
- (B) Kingdom
- (C) Genus
- (D) Order

45. Ex situ conservation methods for plants could be practised by all of the following methods EXCEPT

- (A) establishing botanic gardens
- (B) keeping them in arboreta
- (C) cultivating them in protected areas of their habitat
- (D) establishing seed banks

**IF YOU FINISH BEFORE TIME IS CALLED, CHECK YOUR WORK ON THIS TEST.**

Listing of Form Section Data  
Caribbean Examinations Council (CXC)

Test: **CAPE BIOLOGY (U1)** (MC ITEMS) Form: **02107010-SPEC2017**

Version No: **1**

Item No.	Key	Syllabus Reference	Profile	Module
1	A	1.1	P1	M1
2	B	1.4	P1	M1
3	B	1.6	P1	M1
4	C	1.7	P2	M1
5	D	1.8	P1	M1
6	A	1.9	P2	M1
7	C	2.2	P1	M1
8	B	2.4	P2	M1
9	A	2.5	P1	M1
10	A	2.6	P1	M1
11	C	3.1	P2	M1
12	C	3.2	P2	M1
13	D	4.3	P2	M1
14	C	4.4	P1	M1
15	C	4.3	P2	M1
16	D	1.1	P1	M2
17	A	1.3	P2	M2
18	D	2.1	P1	M2
19	C	1.4	P2	M2
20	A	2.5	P2	M2
21	B	2.6	P1	M2
22	B	3.1	P2	M2
23	C	3.2	P1	M2
24	D	3.5	P1	M2
25	A	3.6	P1	M2
26	B	4.3	P2	M2
27	D	4.5	P1	M2
28	B	4.7	P2	M2
29	C	4.10	P1	M2
30	A	4.12	P2	M2

Listing of Form Section Data  
Caribbean Examinations Council (CXC)

Test: **CAPE BIOLOGY (U1)** (MC ITEMS) Form: **02107010-SPEC2017**

Version No: **1**

Item No.	Key	Syllabus Reference	Profile	Module
31	A	1.1	P2	M3
32	A	1.2	P2	M3
33	C	1.2	P1	M3
34	C	2.1	P2	M3
35	D	2.2	P1	M3
36	C	2.2	P2	M3
37	D	2.4	P2	M3
38	A	2.5	P2	M3
39	C	2.7	P2	M3
40	D	2.8	P1	M3
41	A	3.2	P2	M3
42	D	3.3	P1	M3
43	C	1.2	P1	M3
44	C	3.3	P1	M3
45	C	4.3	P1	M3

CARIBBEAN EXAMINATIONS COUNCIL

CARIBBEAN ADVANCED PROFICIENCY EXAMINATION®

“\*”Barcode Area”  
Front Page Bar Code

SPECIMEN PAPER

FILL IN ALL THE INFORMATION REQUESTED CLEARLY IN CAPITAL LETTERS.

TEST CODE 

0	2	1	0	7	0	2	0
---	---	---	---	---	---	---	---

SUBJECT BIOLOGY – UNIT 1 – Paper 02

PROFICIENCY ADVANCED

REGISTRATION NUMBER 

--	--	--	--	--	--	--	--	--	--

SCHOOL/CENTRE NUMBER  

--	--	--	--	--	--

NAME OF SCHOOL/CENTRE  

--

CANDIDATE’S FULL NAME (FIRST, MIDDLE, LAST)  

--

“\*”Barcode Area”  
Current Bar Code

DATE OF BIRTH 

D	D	M	M	Y	Y	Y	Y
---	---	---	---	---	---	---	---

SIGNATURE \_\_\_\_\_

“\*”Barcode Area”  
Sequential Bar Code

**DO NOT  
WRITE ON  
THIS PAGE**

SPEC 2017/02107020



TEST CODE 02107020

CARIBBEAN EXAMINATIONS COUNCIL

CARIBBEAN ADVANCED PROFICIENCY EXAMINATION®

BIOLOGY

UNIT 1 – Paper 02

*2 hours 30 minutes*

**READ THE FOLLOWING INSTRUCTIONS CAREFULLY.**

1. This paper consists of THREE questions. Answer ALL questions.
2. Write your answers in the spaces provided in this booklet.
3. Do NOT write in the margins.
4. You may use a silent, non-programmable calculator to answer questions.
5. You are advised to take some time to read through the paper and plan your answers.
6. If you need to rewrite any answer and there is not enough space to do so on the original page, you must use the extra lined page(s) provided at the back of this booklet. **Remember to draw a line through your original answer.**
7. **If you use the extra page(s), you MUST write the question number clearly in the box provided at the top of the extra page(s) and, where relevant, include the question part beside the answer.**

**DO NOT TURN THIS PAGE UNTIL YOU ARE TOLD TO DO SO.**

Copyright © 2017 Caribbean Examinations Council  
All rights reserved.

02107020/CAPE/SPEC 2017

“\*”Barcode Area”\*”  
Sequential Bar Code



**Module I**

**Answer ALL questions.**

**Write your answers in the spaces provided in this booklet.**

1. (a) (i) Students are given five test tubes containing either water, 0.25% sucrose solution, 1% sucrose solution, 1% glucose solution or starch solution. They perform tests for reducing sugar, non-reducing sugar and starch. By the end of the experiment, all the labels have fallen off the test tubes.

Given the results in Table 1, identify the solution that is in EACH test tube and give a reason for answer.

**TABLE 1: RESULTS OF TESTS**

Test Tube Number	Benedict's solution	Benedict's solution, dilute HCL, Sodium Bicarbonate	Iodine Test
1	Remains blue	Blue-green colour change	Yellow-brown colour
2	Blue-green-yellow-orange colour change	Blue-green-yellow-orange colour change	Yellow-brown colour
3	Remains blue	Blue-green-yellow-orange colour change	Yellow-brown colour
4	Remains blue	Remains blue	Yellow-brown colour
5	Remains blue	Remains blue	Blue-black colour

Test Tube 1 .....

.....  
.....

Test Tube 2 .....

.....  
.....

GO ON TO THE NEXT PAGE

Test Tube 3 .....

.....

.....

Test Tube 4 .....

.....

.....

Test Tube 5 .....

.....

.....

[5 marks]

- (ii) Explain the reaction occurring in Test Tubes 1 and 3 to allow for the colour change in Column 3.

Name of reaction .....

Explanation .....

.....

.....

.....

[2 marks]

DO NOT WRITE IN THIS AREA

- (b) (i) Figure 1 compares the enzyme activity for amylase on starch with and without the addition of an inhibitor. What type of inhibitor was most likely added to the enzymatic reaction represented by Curve A?

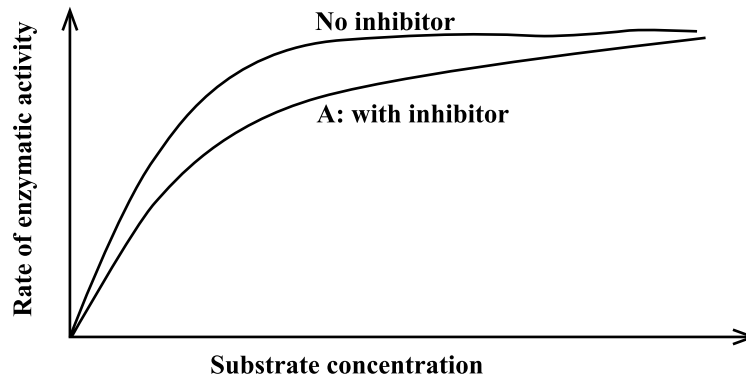

Figure 1: Graph showing enzymatic activity with and without an inhibitor

[1 mark]

DO NOT WRITE IN THIS AREA

- (ii) Although enzymes can be classified as globular proteins, not all globular proteins, for example, haemoglobin, are enzymes. Using your knowledge of protein structure, describe THREE protein structural levels present in haemoglobin. Include in your description, the bonds present at EACH structural level.

.....

.....

.....

.....

.....

.....

.....

.....

.....

.....

.....

.....

.....

.....

.....

.....

.....

.....

.....

.....

.....

[6 marks]

- (iii) Haemoglobin is a major component of red blood cells, which are examples of eukaryotic cells. A student makes the following observations of two given cell types:

Observations

Cell 1 contains DNA, ribosomes, cell membrane and cell wall

Cell 2 contains DNA, ribosomes, Golgi apparatus, rough endoplasmic reticulum, cell membrane and cell wall.

From these observations, indicate the cell that is prokaryotic and the cell that is eukaryotic.

Prokaryotic .....

Eukaryotic .....

[1 mark]

GO ON TO THE NEXT PAGE

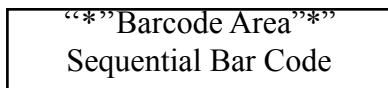

(iv) State the function of EACH of the following structures:

Ribosomes .....

.....

Golgi apparatus .....

.....

Rough endoplasmic reticulum .....

.....

.....

[3 marks]

(c) The structure and composition of the cell membrane govern cell transport, the model for which is referred to as a fluid mosaic membrane (FMM) model. A beaker has a cell encased by a cell membrane only. A solution containing water molecules (higher water potential than in the cell), potassium ions (lower concentration than in the cell) and glucose (higher concentration than in the cell) is poured into the beaker. With reference to the FMM model, explain how these substances are taken up by the cell.

.....

.....

.....

.....

.....

.....

.....

.....

.....

.....

.....

.....

.....

.....

.....

.....

.....

.....

.....

.....

.....

.....

.....

GO ON TO THE NEXT PAGE

DO NOT WRITE IN THIS AREA

**DO NOT WRITE IN THIS AREA** **DO NOT WRITE IN THIS AREA** **DO NOT WRITE IN THIS AREA**

(This area contains multiple horizontal dotted lines for writing.)

**[12 marks]**

**Total 30 marks**

“\*” Barcode Area \*”  
Sequential Bar Code

**Module 2**

2. (a) Figure 2 shows four stages of Meiosis I in developing anther cells.

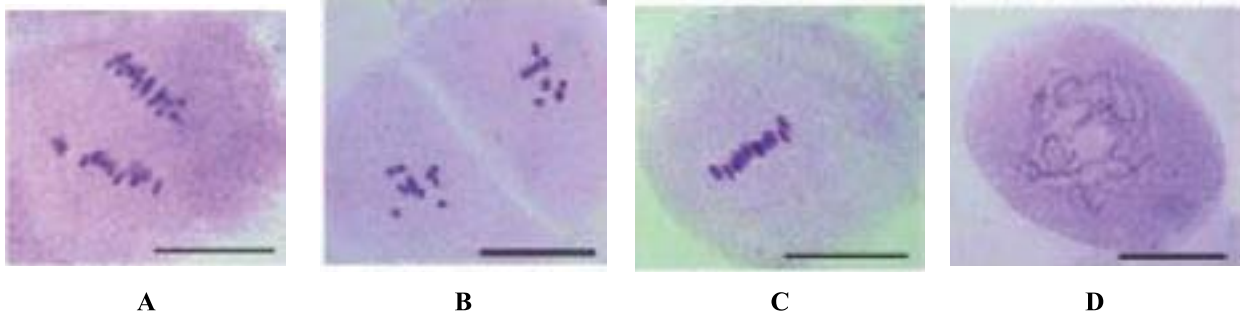

**Figure 2. Stages of Meiosis I in developing anther cells.**

*Source: J Exp Bot. 2012 Sep;63(14): 5323–5335*

(i) Order the images to illustrate the sequential steps in the process.

.....  
[1 mark]

(ii) Label the structures in Stage B.

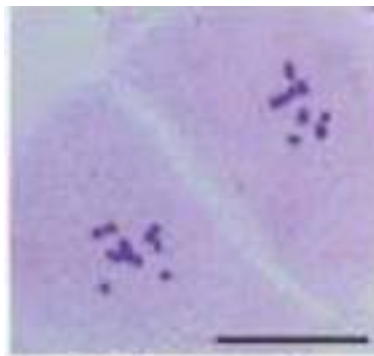

**Stage B**

[3 marks]

GO ON TO THE NEXT PAGE

- (iii) Indicate the stage at which crossing-over events can occur, and explain how crossing-over events lead to genetic variation.

Stage at which crossing over can occur .....

Crossing over and variation .....

[5 marks]

DO NOT WRITE IN THIS AREA





Advantages .....

.....  
.....  
.....  
.....  
.....  
.....  
.....  
.....  
.....  
.....  
.....  
.....

[8 marks]

- (c) R-DNA technology is an artificial process that can introduce changes in organisms. Some changes, however, can occur naturally over time. Using named examples, discuss the isolating mechanisms that arise in populations which may lead to them becoming two different species.

.....  
.....  
.....  
.....  
.....  
.....  
.....  
.....  
.....  
.....  
.....  
.....  
.....  
.....  
.....  
.....  
.....  
.....  
.....

GO ON TO THE NEXT PAGE

“\*”Barcode Area”\*  
Sequential Bar Code

DO NOT WRITE IN THIS AREA

DO NOT WRITE IN THIS AREA

DO NOT WRITE IN THIS AREA

A series of horizontal dotted lines providing space for writing answers.

[13 marks]

Total 30 marks

GO ON TO THE NEXT PAGE

“\*”Barcode Area\*”  
Sequential Bar Code

DO NOT WRITE IN THIS AREA

**Module 3**

3. (a) Table 2 is an incomplete table for four hormones in the human body. Complete the table by writing the correct information in each column.

**TABLE 2: HORMONES IN THE HUMAN BODY**

<b>Hormone</b>	<b>Individual</b>	<b>Site of Production</b>	<b>Target Organ</b>	<b>Action</b>
Follicle-stimulating hormone (FSH)	Male			
FSH	Female			
Lutenising hormone (LH)	Male			
LH	Female			
Oestrogen	Male			
Oestrogen	Female			
Progesterone	Male			
Progesterone	Female			

[8 marks]

GO ON TO THE NEXT PAGE

- (b) Figure 3 shows the structure of a human oocyte. Write annotations for the parts labelled 1, 2 and 3.

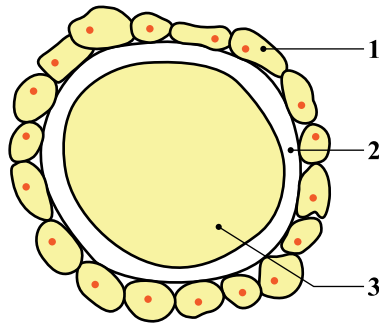

Figure 3. Cross section of a human ovary

1 .....

2 .....

3 .....

[3 marks]

GO ON TO THE NEXT PAGE

(c) A couple wants to have children but not immediately after marriage.

(i) For pregnancy to take place, fertilization must occur but the vagina is a hostile environment for sperms. Explain how sperms overcome the structural and adverse conditions to fertilize the egg.

.....

.....

.....

.....

.....

.....

.....

.....

.....

.....

.....

.....

.....

.....

.....

.....

.....

.....

.....

[7 marks]

(ii) Identify FOUR contraceptive methods that may be suitable for the couple, and using your knowledge of the human reproductive system, discuss the structural and physiological means by which they prevent fertilization.

.....

.....

.....

.....

.....

.....

.....

.....

.....

GO ON TO THE NEXT PAGE

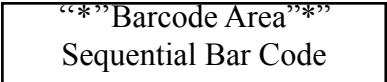

DO NOT WRITE IN THIS AREA



Series of horizontal dotted lines for writing.

DO NOT WRITE IN THIS AREA

GO ON TO THE NEXT PAGE

02107020/CAPE/SPEC 2017



“\*” Barcode Area “\*”  
Sequential Bar Code



DO NOT WRITE IN THIS AREA

DO NOT WRITE IN THIS AREA

DO NOT WRITE IN THIS AREA

.....

.....

.....

.....

.....

.....

.....

.....

.....

.....

.....

.....

.....

.....

.....

.....

.....

.....

[12 marks]

Total 30 marks

**END OF TEST**

**IF YOU FINISH BEFORE TIME IS CALLED, CHECK YOUR WORK ON THIS TEST.**

“*”Barcode Area”*” Sequential Bar Code
---



**EXTRA SPACE**

If you use this extra page, you **MUST** write the question number clearly in the box provided.

Question No.

Dotted lines for writing.

DO NOT WRITE IN THIS AREA

**Barcode Area**  
Sequential Bar Code

EXTRA SPACE

If you use this extra page, you MUST write the question number clearly in the box provided.

Question No.

Ruled area for writing with horizontal dotted lines.

DO NOT WRITE IN THIS AREA

Barcode Area  
Sequential Bar Code

EXTRA SPACE

If you use this extra page, you **MUST** write the question number clearly in the box provided.

Question No.

.....

.....

.....

.....

.....

.....

.....

.....

.....

.....

.....

.....

.....

.....

.....

.....

.....

.....

.....

.....

.....

.....

DO NOT WRITE IN THIS AREA

“\*” Barcode Area ”\*  
Sequential Bar Code

**DO NOT  
WRITE ON  
THIS PAGE**

“\*”Barcode Area”  
Sequential Bar Code

**CANDIDATE'S RECEIPT**

**INSTRUCTIONS TO CANDIDATE:**

- 1. Fill in all the information requested clearly in capital letters.**

TEST CODE: 

0	2	1	0	7	0	2	0
---	---	---	---	---	---	---	---

SUBJECT: BIOLOGY – UNIT 1 – Paper 02

PROFICIENCY: ADVANCED

REGISTRATION NUMBER: 

--	--	--	--	--	--	--	--	--	--

FULL NAME: \_\_\_\_\_  
**(BLOCK LETTERS)**

Signature: \_\_\_\_\_

Date: \_\_\_\_\_

- 2. Ensure that this slip is detached by the Supervisor or Invigilator and given to you when you hand in this booklet.**
- 3. Keep it in a safe place until you have received your results.**

**INSTRUCTION TO SUPERVISOR/INVIGILATOR:**

Sign the declaration below, detach this slip and hand it to the candidate as his/her receipt for this booklet collected by you.

I hereby acknowledge receipt of the candidate's booklet for the examination stated above.

Signature: \_\_\_\_\_  
Supervisor/Invigilator

Date: \_\_\_\_\_

**DO NOT  
WRITE ON  
THIS PAGE**

**CANDIDATE'S RECEIPT**

**INSTRUCTIONS TO CANDIDATE:**

1. **Fill in all the information requested clearly in capital letters.**

TEST CODE: 

0	2	1	0	7	0	2	0
---	---	---	---	---	---	---	---

SUBJECT: BIOLOGY – UNIT 1 – Paper 02

PROFICIENCY: ADVANCED

REGISTRATION NUMBER: 

--	--	--	--	--	--	--	--	--	--

FULL NAME: \_\_\_\_\_  
**(BLOCK LETTERS)**

Signature: \_\_\_\_\_

Date: \_\_\_\_\_

2. **Ensure that this slip is detached by the Supervisor or Invigilator and given to you when you hand in this booklet.**
3. **Keep it in a safe place until you have received your results.**

**INSTRUCTION TO SUPERVISOR/INVIGILATOR:**

Sign the declaration below, detach this slip and hand it to the candidate as his/her receipt for this booklet collected by you.

I hereby acknowledge receipt of the candidate's booklet for the examination stated above.

Signature: \_\_\_\_\_  
Supervisor/Invigilator

Date: \_\_\_\_\_



C A R I B B E A N            E X A M I N A T I O N S            C O U N C I L

CARIBBEAN ADVANCED PROFICIENCY EXAMINATION®

BIOLOGY

UNIT 1 - Paper 02

KEYS AND MARK SCHEME

MAY/JUNE 2018

## BIOLOGY

## UNIT 1 - PAPER 02

## MARK SCHEME

Question 1 Sp. Obj. 1.9, 1.2, 4.4, 1.10, 1.11, 2.2, 2.3, 2.1, 3.1, 3.2

(a) (i) **Test Tube 1:** 0.25% sucrose. It was positive for non-reducing sugar but negative for reducing sugar and iodine test, like Test Tube 3. However, the colour change was less intense than Test Tube 3.

**Test Tube 2:** 1% glucose. It was positive for reducing sugar and non-reducing sugar test and negative for iodine test.

**Test Tube 3:** 1% sucrose. It was negative for reducing sugar and iodine, and positive for non-reducing sugar. The colour change more intense than Test Tube 1.

**Test tube 4:** Water, negative for all tests

**Test tube 5:** Starch. It was positive only for the iodine test which means starch was present.

**1 mark for each = 5 marks**

**[5]**

(ii) The process of **hydrolysis** took place in these test tubes

**1 mark**

Breaking of glycosidic bonds found in sucrose changes sucrose from a non-reducing sugar into a reducing sugar allowing colour change to occur because of the presence of the Benedict's solution.

**1 mark**

**[2]**

(b) (i) The type of inhibitor is **competitive 1 mark**

**[1]**



## BIOLOGY

## UNIT 1 - PAPER 02

## MARK SCHEME

- (ii) Primary structure: chain of polypeptide, sequence of amino acids held together by peptide bonds.

**2 marks (1 mark if no mention of peptide bonds)**

Secondary structure: alpha helices and beta sheets held together by hydrogen bonds

**2 marks (1 mark if hydrogen bonds or alpha helices or beta sheets are missing)**

Tertiary structure: three-dimensional structure, folding of alpha helices and beta sheets into a 3-D structure or subunit held together by hydrogen bonds, covalent bonds, ionic bonds, disulphide bridges, van der waal forces.

**2 marks (1 mark if less than 3 types of bonds are mentioned)**

Quaternary structure: multiple subunits or tertiary structures coming together to make a functional protein held together by hydrogen bonds, covalent bonds, ionic bonds, disulphide bridges, van der waal forces.

**2 marks (1 mark if less than 3 types of bonds are mentioned)**

**Any 3 levels = 6 marks**

**[6]**

- (iii) Prokaryotic - Cell 1  
Eukaryotic - Cell 2

**1 mark for both correct**

**[1]**

- (iv) Ribosomes: site of protein synthesis

Golgi apparatus: involved in packaging of substances for transport in the cell, modifies substances from the endoplasmic reticulum

Rough endoplasmic reticulum: protein synthesis

**1 mark each = 3 marks**

**[3]**

## BIOLOGY

## UNIT 1 - PAPER 02

## MARK SCHEME

(c) Fluid mosaic model

1. Structure of the cell membrane is a bilayer of phospholipids whose orientation results in a layer of hydrophobicity between regions of hydrophilic interactions **(1)** and includes glycolipids, cholesterol, protein, glycoprotein **(1)** and its fluidity, allowing movement of components **(1)**.
2. Given the fact that water, potassium ions and glucose are all polar molecules, they cannot simply diffuse through the membrane due to the hydrophobic region. **(1)**
3. Therefore, there is a need for proteins **(1)** whether as pumps, channels or carrier proteins within the membrane to aid with transport of these molecules into the cell. **(1)**
4. Water is moving from an area of high potential to an area of low potential, thus it will move via passive transport, in particular osmosis **(1)**, and to facilitate this a protein channel is needed/ aquaporin. **(1)**
5. Potassium ions will be moving from an area of low concentration to an area of high concentration, thus active transport is going to take place, meaning that there is a need for ATP **(1)**. To facilitate this, a protein pump is required. **(1)**
6. Glucose is moving from an area of high concentration to an area of low concentration, therefore facilitated diffusion is going to occur. **(1)** To facilitate this movement, either a carrier protein or a protein channel can be used for its transportation. **(1)**

[12]

**Total 30 marks**

## BIOLOGY

## UNIT 1 - PAPER 02

## MARK SCHEME

**Question 2. Sp. Obj.2.6, 4.1, 4.2, 4.4, 5.4, 5.4**

(a) (i) D → C → A → B **1 mark** [1]

(ii) Labelling of Stage B

Labels should show

- cell plate (center)
- cell wall (outer)
- chromosomes

**1 mark each**

[3]

(iii) Crossing over can occur at Stage D (prophase) **1 mark**

Crossing over and variation

- Homologous chromosomes pair and wind around each other.
- Where two chromatids touch each other, the DNA breaks and sections are exchanged between non-sister chromatids. This is called crossing over.
- Crossing over results in chromosomes that are part maternal in origin and part paternal
- This gives different combinations of alleles of different genes - variation.

**1 mark each = 4 marks**

[5]

(b) R-DNA process

1. Isolation of genes: DNA is removed from a host source. (The insulin gene (INS) coding for insulin production is extracted from a sample of human DNA).
2. Enzyme restriction: circular plasmid DNA from a bacterium is "cut" via an endonuclease enzyme that breaks the DNA phosphate backbone making it linear.
3. Ligation: the "pasting together" of (different source) fragments of DNA forming the recombinant DNA molecule... using the ligase enzyme, the human insulin gene is then combined with the linear plasmid DNA and is re-circularized.
4. Uptake of plasmid: uptake of DNA by an organism (bacterium)... the new recombinant DNA is taken-up by other bacteria to facilitate replication of the plasmid.

## BIOLOGY

## UNIT 1 - PAPER 02

## MARK SCHEME

5. Cloning: the subsequent growth (ideal conditions) allows for high production of multiple copies of the new plasmid (R-DNA molecule) and production of the gene product ... insulin.

**1 mark each = 5 marks**

Advantages

1. More efficient process in that higher yields are obtained
2. More cost effective / less expensive
3. No animals have to be slaughtered (cattle, pigs, salmon)
4. Faster, less tedious and less difficult process

**Any 3 = 3 marks**

**[8]**

(c) Isolating mechanisms

1. Temporal - individuals do not mate because they are active at different times of the day or during different seasons. This may have resulted from resource limitations or changes over time.
2. Behavioural / reproductive - potential mates meet but they do not mate due to strict behavioural complexities e.g. mating dances or vocalisations. This may occur where mate choice is not a limitation.
3. Geographical / ecological - Individuals prefer to mate in their desired habitat and therefore do not meet individuals of other ecological preferences. This may happen, for example, when new food sources become available in the habitat. Also, Physical changes in landscape may result in physical barriers which may separate populations.
4. Mechanical - structural differences mean that sex organs of males and females of different species are incompatible.

**3 marks for each mechanism fully discussed**

**1 mark for correct examples**

**[13]**

**Total 30 marks**

## BIOLOGY

## UNIT 1 - PAPER 02

## MARK SCHEME

Question 3. Sp. Obj.2.2, 2.6, 2.3, 2.7

(a)

Hormone	Individual	Site of Production	Target Organ	Action
Follicle-stimulating hormone (FSH)	Male	Anterior pituitary gland	Testes	Stimulates Sertoli cells to develop sperm cells
FSH	Female	Anterior pituitary gland	Ovary	Stimulates oogenesis
Lutenising hormone (LH)	Male	Anterior pituitary gland	Testes interstitial cells	Stimulates interstitial cells to secrete testosterone
LH	Female	Anterior pituitary gland	Ovary follicle	Stimulates release of secondary oocyte at ovulation
Oestrogen	Male	Testes interstitial cells	Testes and epididymis	Regulates spermatogenesis and sperm maturation in epididymis
Oestrogen	Female	Follicle in ovary	Uterus	Stimulates repair and growth of endometrium; stimulates growth and

## BIOLOGY

## UNIT 1 - PAPER 02

## MARK SCHEME

				development of primary and secondary sexual characteristics
Progesterone	Male	Testes	Seminiferous tubules	Helps regulate sperm production; increases sperm motility
Progesterone	Female	Corpus luteum in ovary	Uterus	Maintains endometrium

**1 mark for each correct row = 8 marks**

**[8]**

(b) Structure of oocyte

1. Follicle cells - form a protective layer around the oocyte
2. Zona pellucida - a clear jelly-like protective layer through which spermatozoa must penetrate
3. Oocyte - contains chromosomes which still have to complete their meiotic divisions

**1 mark for each part annotated = 3 marks**

**[3]**

(c) (i) Fertilization

1. The pH of the vagina is low and tends to kill sperms. They are able to move as a mass through the cervix because the semen coagulates immediately after ejaculation.
2. The sperms must travel a far distance to the ovarian end of the oviduct. They are aided by the contractions of the cervix, uterus and oviduct.
3. During the fertile period, the cervical mucus forms channels for the mass of sperms to swim through.
4. Sperms must go through a process called capacitation - glycoproteins are removed from the outer surface and the membranes become more permeable to calcium ions
5. The calcium ions increase their motility, and help the release of enzymes from the acrosome.
6. The enzymes digest a pathway through the follicle cells to the surface membrane of the oocyte.

BIOLOGY

UNIT 1 - PAPER 02

MARK SCHEME

7. The membranes of the sperm and oocyte fuse.

**1 mark each = 7 marks**

**[7]**

(ii) Contraceptives

1. Barrier - condom/femidom placed over the penis/into the vagina which prevents sperms from entering the vagina during intercourse
2. Diaphragm/cap - placed over the cervix to prevent sperms from entering the cervix
3. Intrauterine device - releases progesterone which prevents implantation of the fertilized egg (controls the lining of the uterus)
4. Spermicides - chemicals that destroy the sperms to prevent them from reaching the egg
5. Contraceptive pill - contains one or both ovarian hormone to prevent ovulation

**3 marks for each of 4 methods = 12 marks**

**[12]**

**Total 30 marks**

CARIBBEAN EXAMINATIONS COUNCIL

CARIBBEAN ADVANCED PROFICIENCY EXAMINATION®

“\*”Barcode Area\*”  
Front Page Bar Code

SPECIMEN PAPER

FILL IN ALL THE INFORMATION REQUESTED CLEARLY IN CAPITAL LETTERS.

TEST CODE 

0	2	1	0	7	0	3	2
---	---	---	---	---	---	---	---

SUBJECT BIOLOGY – UNIT 1 – Paper 032

PROFICIENCY ADVANCED

REGISTRATION NUMBER 

--	--	--	--	--	--	--	--	--	--

SCHOOL/CENTRE NUMBER  

--	--	--	--	--	--

NAME OF SCHOOL/CENTRE  

--

CANDIDATE’S FULL NAME (FIRST, MIDDLE, LAST)  

--

DATE OF BIRTH 

D	D	M	M	Y	Y	Y	Y
---	---	---	---	---	---	---	---

SIGNATURE \_\_\_\_\_

“\*”Barcode Area\*”  
Current Bar Code

“\*”Barcode Area\*”  
Sequential Bar Code



**DO NOT  
WRITE ON  
THIS PAGE**

SPEC 2017/02107032



TEST CODE 02107032

CARIBBEAN EXAMINATIONS COUNCIL

CARIBBEAN ADVANCED PROFICIENCY EXAMINATION®

BIOLOGY - SPECIMEN PAPER

UNIT 1 – Paper 032

ALTERNATIVE TO SCHOOL-BASED ASSESSMENT

*2 hours*

**READ THE FOLLOWING INSTRUCTIONS CAREFULLY.**

1. This paper consists of THREE questions. Answer ALL questions.
2. Write your answers in the spaces provided in this booklet.
3. Do NOT write in the margins.
4. You may use a silent, non-programmable calculator to answer questions.
5. You are advised to take some time to read through the paper and plan your answers.
6. If you need to rewrite any answer and there is not enough space to do so on the original page, you must use the extra lined page(s) provided at the back of this booklet. **Remember to draw a line through your original answer.**
7. **If you use the extra page(s), you MUST write the question number clearly in the box provided at the top of the extra page(s) and, where relevant, include the question part beside the answer.**

**DO NOT TURN THIS PAGE UNTIL YOU ARE TOLD TO DO SO.**

---

Copyright © 2017 Caribbean Examinations Council  
All rights reserved.

02107032/CAPE/SPEC 2017

“\*”Barcode Area”\*”  
Sequential Bar Code

Answer ALL questions.

Write your answers in the spaces provided in this booklet.

Please begin Question 1 FIRST.

1. You are to carry out a simple investigation into the effect of different concentrations of a sucrose solution on the tissue of the cucumber fruit. Read the instructions that follow carefully before beginning.

You are provided with the following:

- 0.1 M, 0.2 M, 0.3 M, 0.4 M, 0.5 M of a sucrose solution
- cucumber (unpeeled)
- 5 petri dishes

Remove ten, 2 cm deep sections that are 5 cm long from the cucumber provided, as shown in Figure 1 (i) and (ii) below.

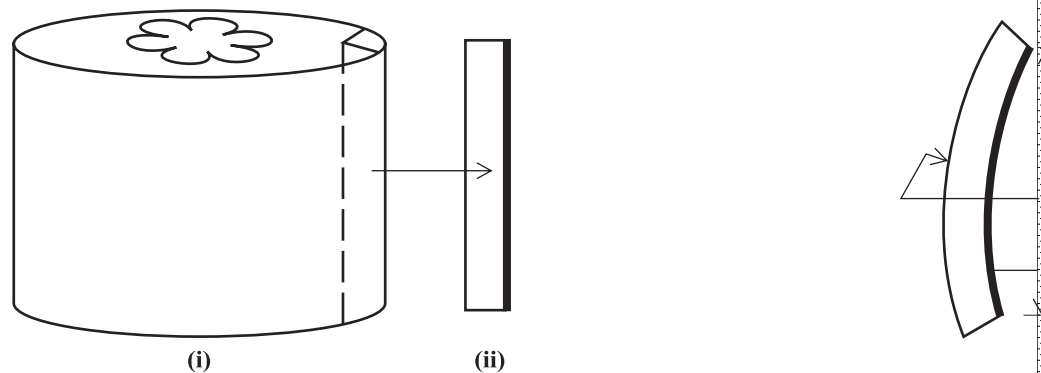

Figure 1. Sections cut from a cucumber

Each strip should have a tough covering of cuticularized epidermis, while the inner part is composed of cortical parenchyma cells.

As soon as the strip is cut out of the cucumber, it bends backwards as shown in Figure 2.

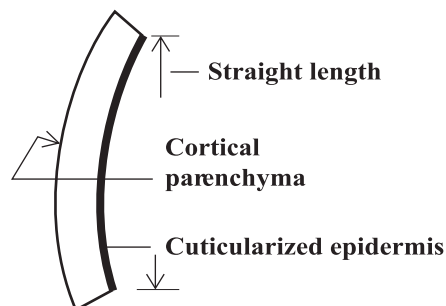

Figure 2

Measure the straight length of the epidermal strips and record the results.

GO ON TO THE NEXT PAGE

Place TWO (2) strips in each of the five petri dishes and treat as follows:

Petri Dish	Treatment
A	cover with sucrose solution 0.1 M
B	cover with sucrose solution 0.2 M
C	cover with sucrose solution 0.3 M
D	cover with sucrose solution 0.4 M
E	cover with sucrose solution 0.5 M

The cucumber strips should be completely submerged in the solutions.

Cover each petri dish and leave for 30 minutes.

CONTINUE WITH THE REST OF THE EXAMINATION IN THE MEANTIME

After the 30 minutes have elapsed, measure the straight lengths of the strips in Petri Dish A and find the average length. Repeat for the other strips in the remaining petri dishes.

- (a) Construct a table to show your results which will include the following: sucrose concentrations, initial length of strips, final length of strips and average length of strips in each concentration.

[6 marks]

GO ON TO THE NEXT PAGE

- (b) Which sucrose solution has a water potential CLOSEST to that of the cucumber?

..... [1 mark]

- (c) Construct simple line drawings of the strips in sucrose solutions of concentrations:

(i) 0.1 M

[2 marks]

(ii) 0.5 M

[2 marks]

GO ON TO THE NEXT PAGE

DO NOT WRITE IN THIS AREA

- (d) (i) State PRECISELY what happens to the cortical cells in the 0.1 M sucrose solution.

.....

.....

.....

.....

.....

.....

.....

.....

[2 marks]

- (ii) State PRECISELY what happens to the cortical cells in the 0.4 M sucrose solution.

.....

.....

.....

.....

.....

.....

.....

.....

[2 marks]

**Total 15 marks**

GO ON TO THE NEXT PAGE



DO NOT WRITE IN THIS AREA

2. (a) The rates of enzyme-catalysed reactions can be influenced by the pH at which they occur. Table 1 shows the relative reaction rates for salivary amylase and arginase at different pH values.

(i) On the grid provided on page 9, plot a graph of the relative rates for BOTH salivary amylase and arginase.

[5 marks]

**TABLE 1: REACTION RATES FOR TWO ENZYMES**

pH Values	Relative reaction rates	
	Salivary amylase (units)	Arginase (units)
4.5	2.2	0
5.0	5.0	0
5.5	8.0	0.2
6.0	13.0	1.0
6.5	17.0	4.0
7.0	18.0	7.0
7.5	16.0	9.0
8.0	11.0	11.8
8.5	6.0	13.5
9.0	2.0	16.0
9.5		18.0
10.0		17.8
10.5		15.0
11.0		14.0

(ii) Using the graph, determine the optimal pH for

• arginase activity ..... [1 mark]

• salivary amylase activity ..... [1 mark]

GO ON TO THE NEXT PAGE

DO NOT WRITE IN THIS AREA

DO NOT WRITE IN THIS AREA

DO NOT WRITE IN THIS AREA

DO NOT WRITE IN THIS AREA

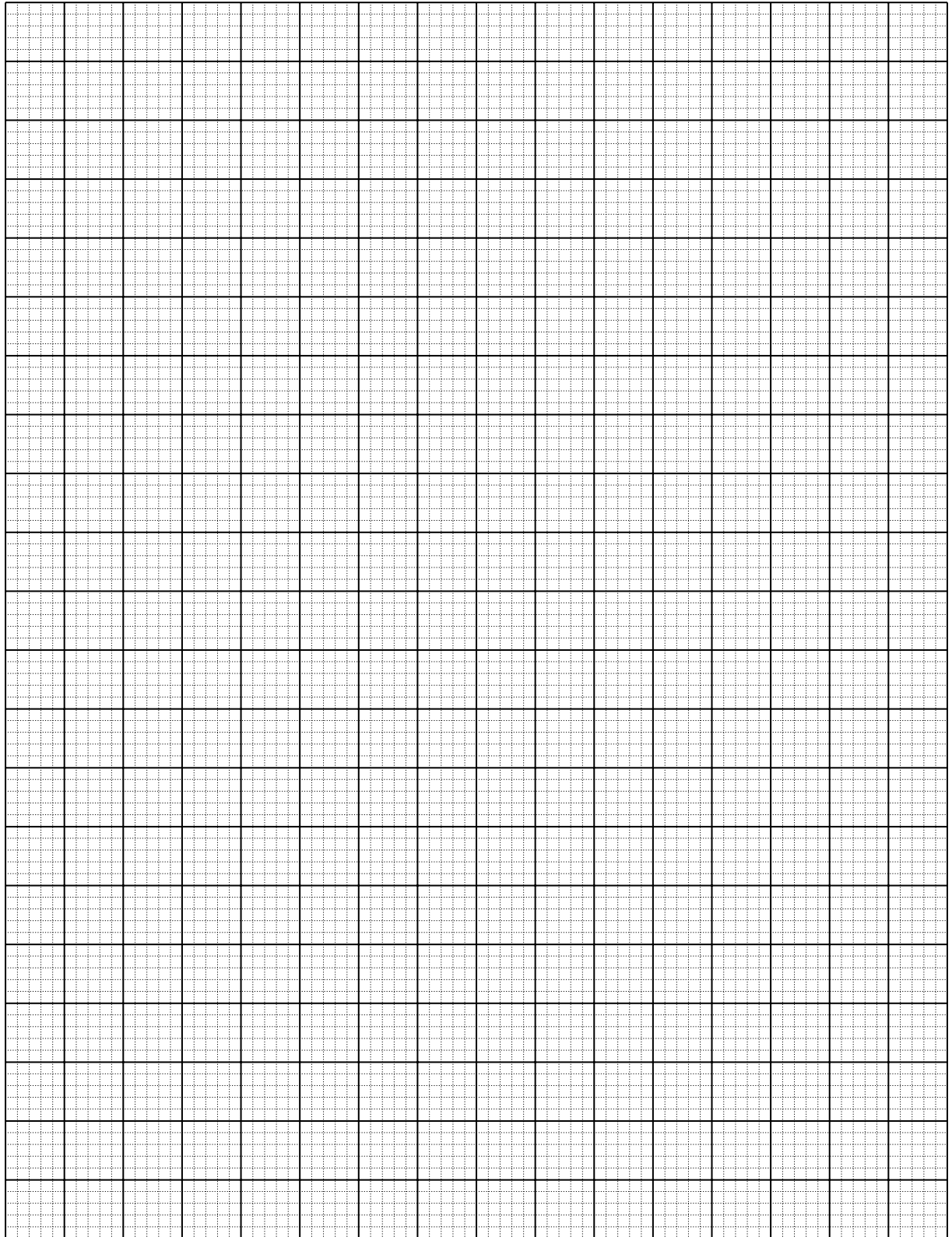

GO ON TO THE NEXT PAGE

“\*”Barcode Area”\*  
Sequential Bar Code



- (iii) Compound X is a substance that has two parts, Part 1 and Part 2. Part 1 can be digested ONLY by arginase and Part 2 ONLY by salivary amylase. Both enzymes are required for the complete digestion of compound X.

Determine the optimal pH at which BOTH of these enzymes together digest compound X.

.....  
[1 mark]

- (iv) Explain the results obtained for salivary amylase at pH 5 and 7.

.....  
[3 marks]

(b)

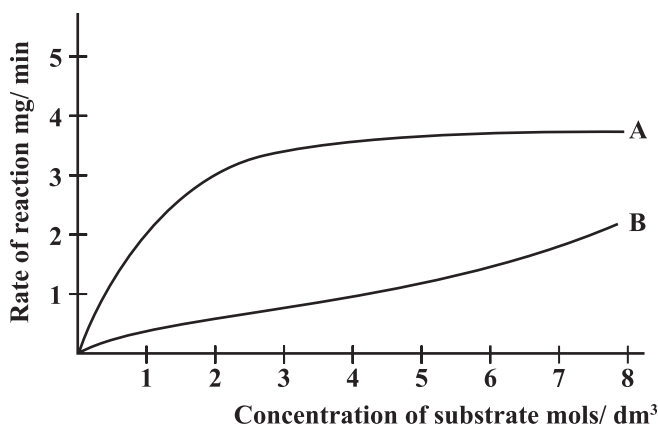

- (i) Which graph line represents the enzyme-catalysed reaction?

.....  
[1 mark]

GO ON TO THE NEXT PAGE

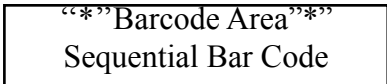

DO NOT WRITE IN THIS AREA

(ii) Give ONE reason for your answer in 2 (a) (i).

.....

.....

.....

.....

.....

.....

.....

.....

.....

**[2 marks]**

(iii) At what concentration of substitute is the rate of reaction MAXIMAL?

.....

.....

**[1 mark]**

**Total 15 marks**

DO NOT WRITE IN THIS AREA

3. A laboratory technician prepared two glucose solutions of different concentrations for a laboratory practical exercise the following day. The technician was called away and when he returned he realised he had not labelled the bottles.

Design an experiment that could help the technician to determine which of the solutions prepared is the more concentrated, if a 1 M solution of glucose from which the following dilution could be prepared: 0.75 M, 0.5 M, 0.25 M.

- (a) List the apparatus that would be required.

.....  
.....  
.....  
.....

[3 marks]

- (b) List the reagents that would be needed.

.....  
.....  
.....  
.....

[2 marks]

- (c) List the steps that should be taken to make a coloured standard.

.....  
.....  
.....  
.....  
.....  
.....  
.....  
.....  
.....  
.....

[4 marks]

GO ON TO THE NEXT PAGE

DO NOT WRITE IN THIS AREA

- (d) Provide a table showing how the results for the coloured standard should be presented.

[3 marks]

- (e) How would the coloured standard be used to determine which solution is more concentrated?  
List the steps:

.....

.....

.....

.....

.....

.....

.....

.....

.....

.....

[3 marks]

**Total 15 marks**

**END OF TEST**

**IF YOU FINISH BEFORE TIME IS CALLED, CHECK YOUR WORK ON THIS TEST.**

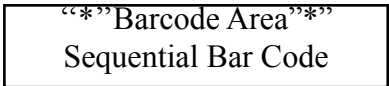

**EXTRA SPACE**

If you use this extra page, you **MUST** write the question number clearly in the box provided.

Question No.

Dotted lines for writing an answer.

Barcode Area  
Sequential Bar Code

DO NOT WRITE IN THIS AREA DO NOT WRITE IN THIS AREA DO NOT WRITE IN THIS AREA

**DO NOT  
WRITE ON  
THIS PAGE**

## CANDIDATE'S RECEIPT

---

### INSTRUCTIONS TO CANDIDATE:

1. **Fill in all the information requested clearly in capital letters.**

TEST CODE: 

0	2	1	0	7	0	3	2
---	---	---	---	---	---	---	---

SUBJECT: BIOLOGY – UNIT 1 – Paper 032

PROFICIENCY: ADVANCED

REGISTRATION NUMBER: 

--	--	--	--	--	--	--	--	--	--

FULL NAME: \_\_\_\_\_  
**(BLOCK LETTERS)**

Signature: \_\_\_\_\_

Date: \_\_\_\_\_

2. **Ensure that this slip is detached by the Supervisor or Invigilator and given to you when you hand in this booklet.**
3. **Keep it in a safe place until you have received your results.**
- 

### INSTRUCTION TO SUPERVISOR/INVIGILATOR:

Sign the declaration below, detach this slip and hand it to the candidate as his/her receipt for this booklet collected by you.

I hereby acknowledge receipt of the candidate's booklet for the examination stated above.

Signature: \_\_\_\_\_  
Supervisor/Invigilator

Date: \_\_\_\_\_

C A R I B B E A N            E X A M I N A T I O N S            C O U N C I L

ADVANCED PROFICIENCY EXAMINATION

BIOLOGY

UNIT 1 - PAPER 032

MARK SCHEME

2017



BIOLOGY

UNIT 1 - PAPER 032

MARK SCHEME

**Question 1.**

(a) Construction of suitable columns.

Table should look similar to table below.

Sucrose Concentration	Strips	Initial Straight Length	Final Straight Length	Average Length
0.1	1			
	2			
0.2	3			
	4			
0.3	5			
	6			
0.4	7			
	8			
0.5	9			
	10			

**Title - 1 mark**

**Construction of table - 2 marks**

Final straight lengths for strips in various concentrations:

0.1M - straight length should decrease very significantly

0.2M - straight length should decrease marginally

0.3M - no significant change in length

0.4M - straight length should increase significantly

0.5M - straight length will decrease

**5 average lengths correct - 3 marks**

**4 average lengths correct - 2 marks**

**3 average lengths correct - 1 mark**

**<3 average lengths correct - 0 marks**

UK	XS
	3
	3

BIOLOGY

UNIT 1 - PAPER 032

MARK SCHEME

Question 1. (continued)

	UK	XS
(c) (i) Diagrams to show how the cucumber strips would look after 30 minutes.		2
0.1M - emphasis on cortical parenchyma		
<b>Cells splitting - 1 mark</b> <b>Correct line representation - 1 mark</b>		2
(ii) 0.5M - emphasis on cuticularized epidermis		
<b>Carving outwards - 1 mark</b> <b>Correct line representation - 1 mark</b>		
(d) (i) <ul style="list-style-type: none"><li>• The 0.1M solution has a higher water potential than the cell sap of the cortical cells of the strip.</li><li>• The water from the solution passes into the cells by osmosis.</li><li>• The cortical cells expand with turgidity.</li><li>• Their increased size causes the inelastic epidermis to be curved back.</li></ul>	2	
<b>3 correct points - 2 marks</b> <b>2 correct points - 1 mark</b> <b>1 correct point - 0 marks</b>		

BIOLOGY

UNIT 1 - PAPER 032

MARK SCHEME

Question 1. (continued)

- (d) (ii)
- Solution 0.5M has a lower potential than the cortical cell sap.
  - Water moves by osmosis from the cortical cells into the bathing solution.
  - The cell vacuole is reduced in volume.
  - The tissue becomes flaccid and draws the inelastic epidermis inwards.
- 3 correct points - 2 marks**  
**2 correct points - 1 mark**  
**1 correct point - 0 marks**

UK	XS
2	

BIOLOGY

UNIT 1 - PAPER 032

MARK SCHEME

Total 18 marks

5	10

Syllabus Objectives: 3.2, 3.3 - Module 1

Question 2.

UK	XS
----	----

BIOLOGY

UNIT 1 - PAPER 032

MARK SCHEME

(a)	(i)	X- and Y-axes correct and properly labelled	1
		Points plotted correctly for <u>salivary amylase</u>	1
		Points plotted correctly for <u>arginase</u>	1
		Curve smoothly drawn for <u>salivary amylase</u>	1
		Curve smoothly drawn for <u>arginase</u>	1
	(ii)	Optimal pH Arginase 9.5 - 10.0 pH	1
		<b>(Any point in this range - 1 mark)</b>	
		Optimal pH Salivary amylase 6.5 - 7.0 pH	1
		<b>(Any point in this range - 1 mark)</b>	
	(iii)	7.6 - 8.4 range	1
		<b>(Any point in this range - 1 mark)</b>	
	(iv)	<ul style="list-style-type: none"><li>pH affect the primary structure of enzymes.</li><li>At pH 7, active site has the correct conformation shape and substrate - enzyme complex can form.</li><li>At pH 5, conformation of active site is altered - enzyme substrate complex can no longer form.</li></ul>	3
		<b>3 points - 3 marks</b>	
(b)	(i)	Graph line A	1
	(ii)	<ul style="list-style-type: none"><li>Rate of reduction shown in graph line A is higher than that for graph line B.</li><li>Rate of reduction increases as substrate concentration increases and then levels off.</li><li>Active sites become saturated.</li></ul>	2
			1

BIOLOGY

UNIT 1 - PAPER 032

MARK SCHEME

All points - 2 marks

Two points - 1 mark

(iii) 4.5 - 5.5 mol/dm<sup>3</sup>

1 mark for value within range above and unit

Total 18 marks

5	10

Syllabus Objectives: 4.1, 4.2, 4.3, 4.5 - Module 1

BIOLOGY

UNIT 1 - PAPER 032

MARK SCHEME

Question 2. (continued)

Graph

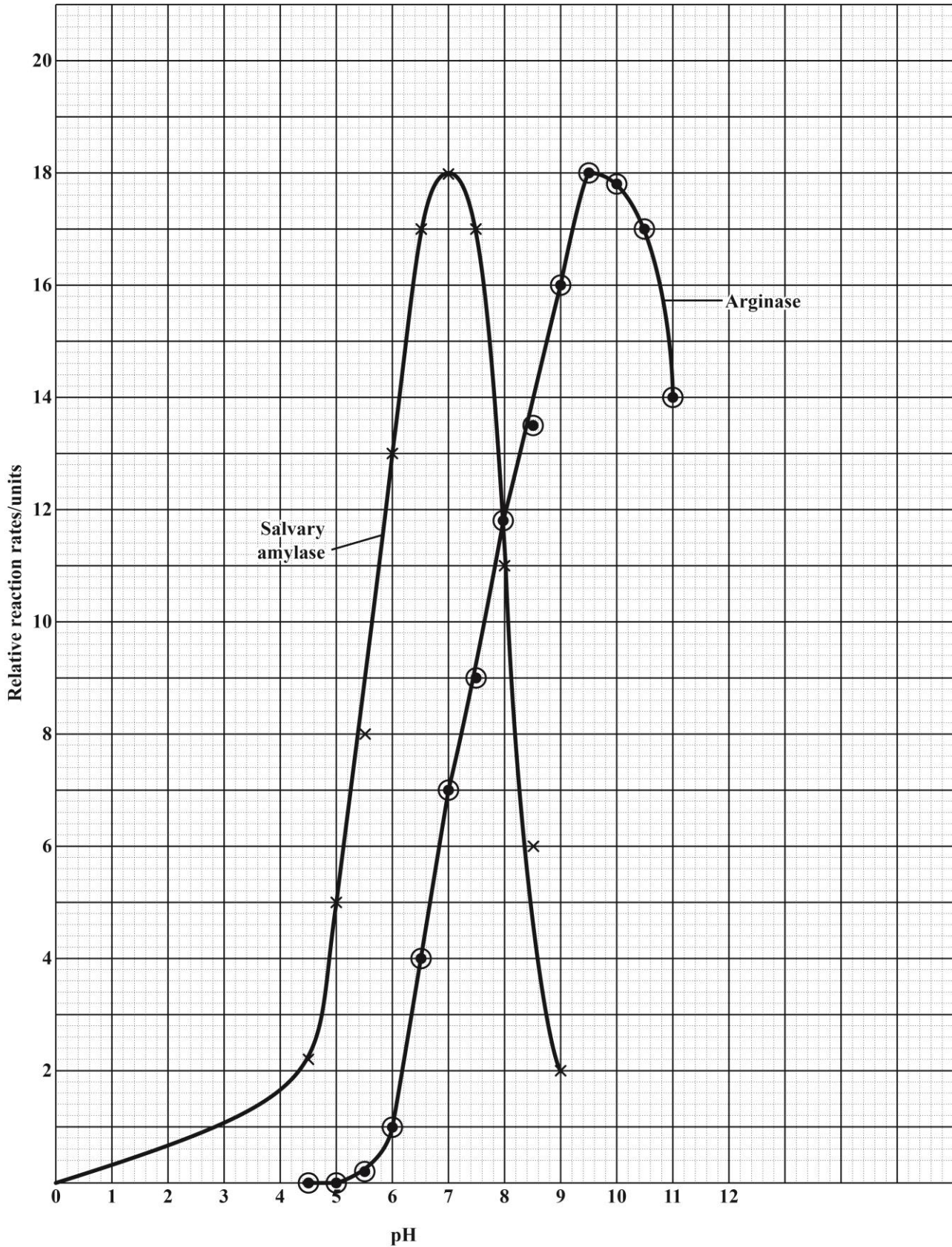

BIOLOGY

UNIT 1 - PAPER 032

MARK SCHEME

Question 3.

(a) Apparatus required:

- Measuring cylinders
- Beakers
- Test tubes
- Test tube holders / test tube racks
- Syringes / pipettes
- Bunsen burner or water bath

**4 points - 3 marks**

**3 points - 2 marks**

**2 points - 1 mark**

(b) Reagents required:

- Benedict's solution
- Distilled water
- Glucose

**3 points - 2 marks**

**1 point - 1 mark**

(c) To make 0.75M glucose solution

- Place 25 cm<sup>3</sup> of distilled water in a measuring cylinder.
- Use a syringe (or pipette) to draw up 75 cm<sup>3</sup> of the 1M glucose solution. Add to the 25 cm<sup>3</sup> of water in the measuring cylinder.
- Place mixture in a labelled beaker.
- To make the other dilutions repeat the procedure above using the ratios given below:

0.5M → 50 cm<sup>3</sup> 1M glucose solution: 50 cm<sup>3</sup> distilled water.

0.25M → 25 cm<sup>3</sup> 1M glucose solution: 75 cm<sup>3</sup> distilled water.

UK	XS
	3
	2
	1
	1
	1



BIOLOGY

UNIT 1 - PAPER 032

MARK SCHEME

- Place 2 ml (1 - 5 ml) of glucose in test tube.
- Add equal amount of Benedict's reagent.
- Heat, record colour

	<b>1</b>
--	----------

Question 3. (continued)

UK	XS
----	----

(d) Table of results

Concentration of glucose (cm)	Colour
1	
0.75	
0.50	
0.25	
0 (distilled water)	

Range of concentrations

1M, 0.75M, 0.50M, 0.25M, 0

**Need all for 2 marks**

**1 missing - 1 mark**

Column headings and liner

- (e)
- Test each solution with Benedict's reagent.
  - Record colour.
  - Apply to coloured standards.

	<b>1</b>
	<b>1</b>
	<b>3</b>

BIOLOGY

UNIT 1 - PAPER 032

MARK SCHEME

**Total 12 marks**

-	12

**Syllabus Objectives: 1.10, 1.11**



**CANDIDATE – PLEASE NOTE!**

PRINT your name below and return this booklet with your answer sheet. Failure to do so may result in disqualification.

TEST CODE **02207010**

**SPEC 2017/02207010**

**CARIBBEAN EXAMINATIONS COUNCIL  
CARIBBEAN ADVANCED PROFICIENCY EXAMINATION®**

**SPECIMEN PAPER  
MULTIPLE CHOICE QUESTIONS  
FOR**

**BIOLOGY**

**UNIT 2 – Paper 01**

**READ THE FOLLOWING INSTRUCTIONS CAREFULLY.**

1. This test consists of 45 items. You will have 1 hour and 30 minutes to answer them.
2. In addition to this test booklet, you should have an answer sheet.
3. Do not be concerned that the answer sheet provides spaces for more answers than there are items in this test.
4. Each item in this test has four suggested answers lettered (A), (B), (C), (D). Read each item you are about to answer and decide which choice is best.
5. On your answer sheet, find the number which corresponds to your item and shade the space having the same letter as the answer you have chosen. Look at the sample item below.

Sample Item

Which of the following is NOT a form of energy storage?

- (A) ATP
- (B) Lipid
- (C) Alcohol
- (D) Lactic acid

Sample Answer



The correct answer to this item is “ATP”, so (A) has been shaded.

6. If you want to change your answer, erase it completely before you fill in your new choice.
7. When you are told to begin, turn the page and work as quickly and as carefully as you can. If you cannot answer an item, go on to the next one. You may return to that item later.
8. You may do any rough work in this booklet.
9. Figures are not necessarily drawn to scale.
10. The use of non-programmable calculators is allowed.

**DO NOT TURN THIS PAGE UNTIL YOU ARE TOLD TO DO SO.**

Copyright © 2017 Caribbean Examinations Council.  
All rights reserved.

1. ATP is often described as the 'universal energy currency of cells'. An important feature of ATP is that it

- (A) takes part in a limited number of reactions of metabolism
- (B) is used only where it is made
- (C) couples catabolic and anabolic processes.
- (D) is released in large amounts

2. When non-cyclic photophosphorylation occurs

- (A) light energy in the green region of the spectrum is absorbed
- (B) carbon dioxide is fixed
- (C) oxygen is produced
- (D) NAD is reduced

3. The products formed at the end of stage 1 in the light dependent reactions of photosynthesis are

- (A) oxygen, ATP and NADP
- (B) oxygen, ATP and reduced NADP
- (C) water, ATP and NADP
- (D) water, ATP and reduced NADP

4. In which of the following reactions of photosynthesis is the first carbohydrate formed?

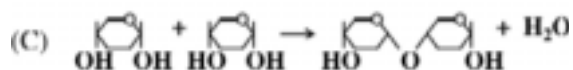
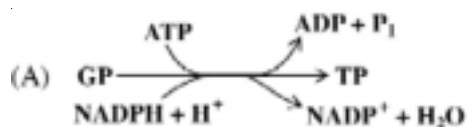

5. The knowledge of the limiting factors which affect the rate of photosynthesis of a particular plant species CANNOT be used directly to

- (A) produce disease resistant plants
- (B) increase the food yield of the plant
- (C) control environmental stress
- (D) control flowering and fruiting

6. Glycolysis requires glucose, the appropriate enzymes and

- (A) reduced NAD
- (B) ATP
- (C) pyruvate
- (D) acetyl co-enzyme A

7. The diagram below represents a mitochondrion. Which of the labels I to IV indicate the sites of Krebs Cycle and the Electron Transport Chain?

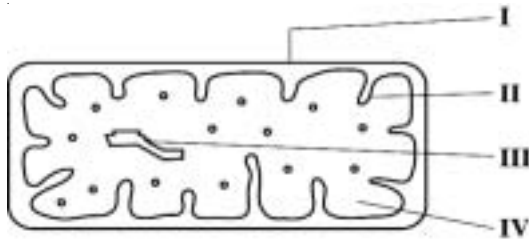

8. Pyruvate produced by glycolysis can only become part of the Krebs cycle if it is first converted to

- (A) NADH
- (B) ethanol
- (C) acetyl-coenzyme A
- (D) citrate

	Krebs Cycle	Electron Transport Chain
--	----------------	-----------------------------

- |     |     |     |
|-----|-----|-----|
| (A) | I   | II  |
| (B) | II  | III |
| (C) | III | IV  |
| (D) | IV  | II  |

---

9. The diagram shows a simple respirometer.

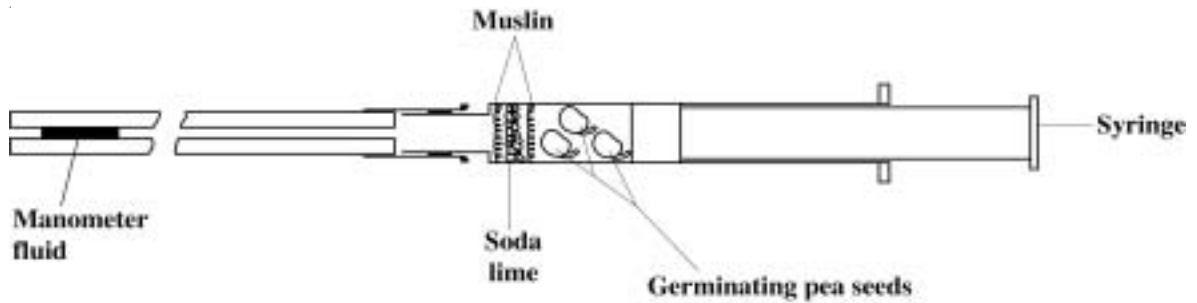

10. Which of the following is NOT a function of anaerobic respiration in yeast?

- (A) Generation of reduced NAD
- (B) Continuation of glycolysis
- (C) Generation of ATP
- (D) Production of carbon dioxide

11. Which of the following BEST describes an ecological niche?

- (A) The relationship between the species and the other organisms in the habitat
- (B) The functional role that the organism plays in its habitat
- (C) The habitat that provides food for the organism
- (D) The habitat that provides the most suitable environmental conditions for the organism

12. Which of the following is considered as a limit to the number of trophic levels in a food chain?

- (A) The diversity of species in the ecosystem
- (B) A high percentage of the energy consumed is converted to heat
- (C) Some of the energy consumed is lost in faeces and urine
- (D) The net productivity of the ecosystem

13. Tree → caterpillars → insectivorous birds → snakes.

Which of the following diagrams represent a pyramid of numbers for the food chain shown above?

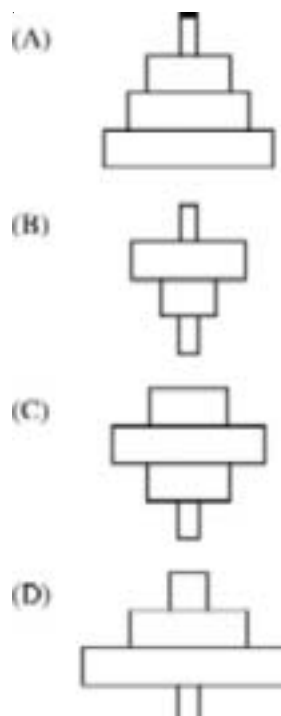

Item 14 refers to the following graph which represents biomass of organisms over a period of time.

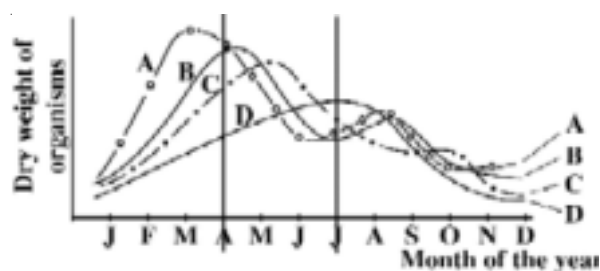

14. If all four trophic levels are represented, which graph would identify plankton?

- (A) A
- (B) B
- (C) C
- (D) D

Item 15 refers to the following diagram which represents part of the nitrogen cycle.

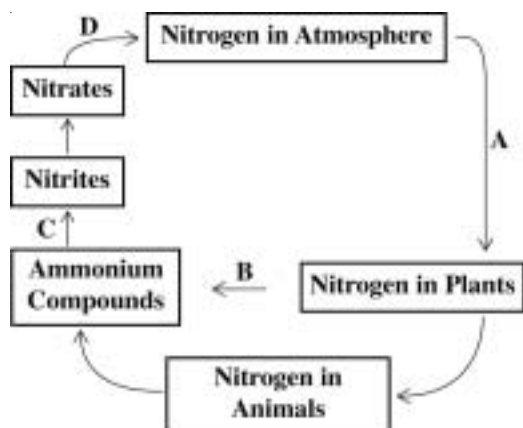

15. Nitrifying bacteria are MOST active at

- (A) A
- (B) B
- (C) C
- (D) D

16. Which of the following is NOT a characteristic feature of xylem vessels?

- (A) No end walls
- (B) Cells end to end
- (C) Thick cellulose cells walls
- (D) No cell contents (hollow)

17. Root pressure, capillarity, cohesion and adhesion all contribute to

- (A) the movement of sucrose along the phloem
- (B) the ascent of water in xylem vessels
- (C) the mass flow of nutrients along sieve elements
- (D) the loss of water via the leaves

Item 18 refers to the figure below showing an outline of some of the cells from the phloem of a mango tree.

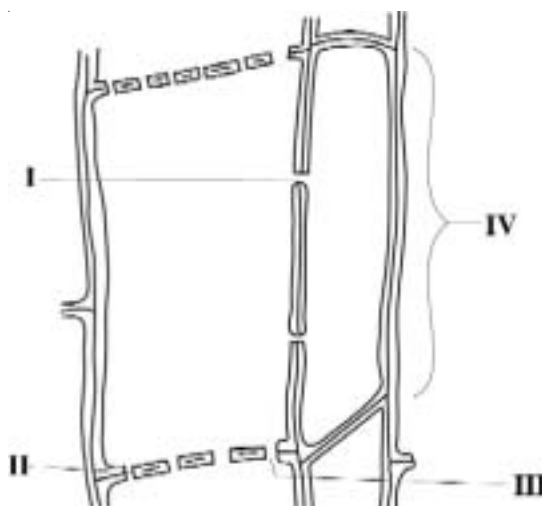

18. Which of the following correctly identifies the structures numbered I to IV?

- |     | I           | II          | III         | IV             |
|-----|-------------|-------------|-------------|----------------|
| (A) | Sieve pore  | sieve tube  | plasmodesma | companion cell |
| (B) | Pasmodesma  | sieve plate | sieve pore  | sieve tube     |
| (C) | Plasmodesma | sieve plate | sieve pore  | companion cell |
| (D) | Seve plate  | sieve pore  | sieve tube  | plasmodesma    |

GO ON TO THE NEXT PAGE

19. Which of the following statements provides the BEST explanation of why sucrose rather than glucose is transported by the phloem?

- (A) Sucrose passes through plant cell surface membranes more easily.
- (B) Sucrose is a disaccharide and is more easily converted to starch.
- (C) Sucrose is a non-reducing sugar and so it is less reactive.
- (D) Sucrose synthesis does not require ATP.

20. The Mass Flow Theory of the transport of organic solutes in the phloem postulates that

- (A) sucrose diffuses from mesophyll cells into the phloem along a concentration gradient
- (B) sucrose moves by osmosis into the phloem when water ascends the xylem into the leaf
- (C) Sucrose is actively pumped by mesophyll cells directly into the phloem against a concentration gradient
- (D) sucrose is actively pumped by companion cells mediating between mesophyll cells and phloem against a concentration gradient

21. In which of the following phases of the cardiac cycle is a pulse generated?

- (A) Atrial systole
- (B) Atrial diastole
- (C) Ventricular systole
- (D) Ventricular diastole

22. Which of the following correctly identifies the mammalian blood cell shown in the diagram below?



- (A) macrophage
- (B) red blood cell
- (C) neutrophil
- (D) lymphocyte

23. The graph below shows the oxygen dissociation curve for human haemoglobin.

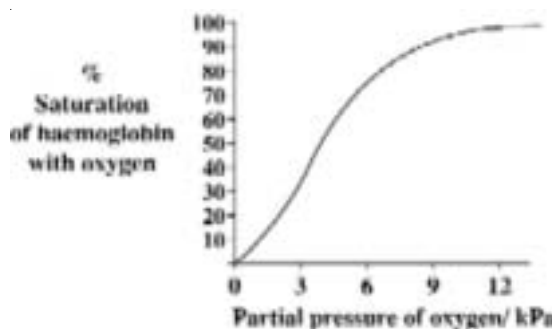

Which of the following ranges of partial pressures of oxygen would be found in pulmonary arteries?

- (A) Between 0 and 3 kPa
- (B) Between 3 and 6 kPa
- (C) Between 6 and 9 kPa
- (D) Between 9 and 12 kPa



24. Which of the following is NOT a function of the liver?

- (A) Production of plasma proteins
- (B) Metabolism of fat
- (C) Control of blood sugar
- (D) Storage of Vitamins B, C and D

Item 25 refers to a micrograph of part of the cortex of the kidney.

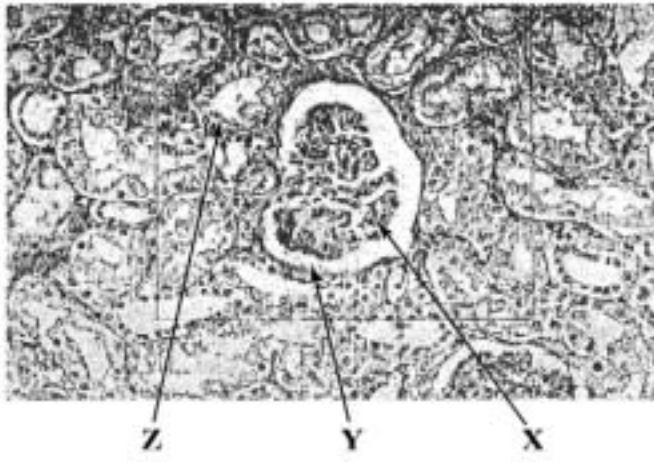

25. Which of the following correctly identifies X, Y and Z?

- |     | X                        | Y                        | Z                        |
|-----|--------------------------|--------------------------|--------------------------|
| (A) | Glomerulus               | distal convoluted tubule | renal capsule            |
| (B) | Distal convoluted tubule | renal capsule            | glomerulus               |
| (C) | Glomerulus               | renal capsule            | distal convoluted tubule |
| (D) | Renal capsule            | Gomerulus                | distal convoluted tubule |

GO ON TO THE NEXT PAGE

26. Which of the following indicates the site and mechanism for the reabsorption of glucose into the blood capillaries from a human kidney nephron?

	Site	Mechanism
(A)	Collecting duct	Active transport
(B)	Distal convoluted tubule	Passive diffusion
(C)	Glomerulus	Selective reabsorption
(D)	Proximal convoluted tubule	Active transport

Item 27 refers to the diagram below.

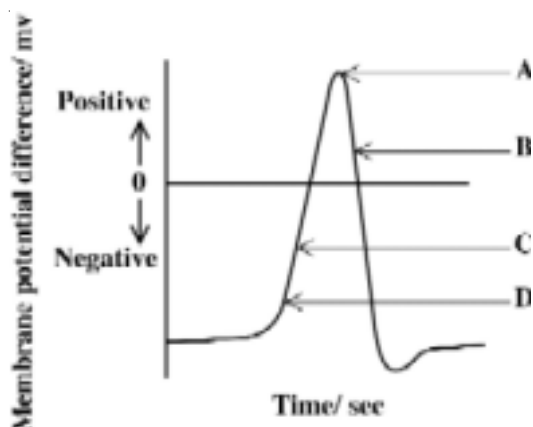

27. The diagram shows the changes in membrane permeability when a stimulus is applied to a neurone. In which region of the action potential A, B, C or D, do sodium ions begin to move in?

28. In a cholinergic synapse, calcium ions ( $\text{Ca}^{2+}$ ) are involved in the transmission of nerve impulses by:

- (A) generating an action potential of +40mv in the postsynaptic knob
- (B) depolarizing the presynaptic knob by entering the neurone
- (C) restoring the resting potential of the neurone by leaving the cell
- (D) triggering the release of neurotransmitter from the synaptic vesicles

29. Which of the following combinations correctly identifies characteristics of both glucagon and insulin?

	Insulin	Glucagon
(A)	Raises blood sugar produced by beta cells	Lowers blood sugar produced by alpha cells
(B)	Reduces blood sugar Produced by alpha cells	Raises blood sugar produced by beta cells
(C)	Reduces blood sugar Produced by beta cells	Raises blood sugar produced by alpha cells
(D)	Raises blood sugar Produced by alpha cells	Reduces blood sugar produced by beta cells

30. Which three of the following combinations correctly describes the features which are typical of endocrine communication?

- I. Transmission is slow
  - II. Response is slow
  - III. Response is reversible
  - IV. Response is widespread
- (A) I, II and III only
  - (B) I, III and IV only
  - (C) II, III and IV only
  - (D) I, II and IV only

GO ON TO THE NEXT PAGE

31. As women pass 50 years of age they require less iron and more calcium in their diets. Which statement provides the BEST explanation for this?

- (A) Blood cells are more readily broken down and must be replaced.
- (B) Women at that age need to replace calcium lost during child bearing years.
- (C) Menstruation is gradually reducing, and bone loss is increasing .
- (D) Less active women would NOT require as many blood cells to be manufactured.

32. During starvation, the FIRST reserve used by the body to maintain energy levels is

- (A) stored glycogen
- (B) protein in muscle
- (C) vitamins stored in liver
- (D) stored fat

33. A student investigates the immediate effects of exercise on the body and records the following results

Time	Pulse/beats min <sup>-1</sup>	Systolic blood pressure/mm Hg
At rest	60	110
5 mins	75	130
10 mins	80	165

Which of the following is the percentage change in blood pressure after 10 minutes of exercise?

- (A) 45%
- (B) 50%
- (C) 55%
- (D) 60%

34. The graph shows the development of an infection with human immunodeficiency virus (HIV) over a period of 10 years.

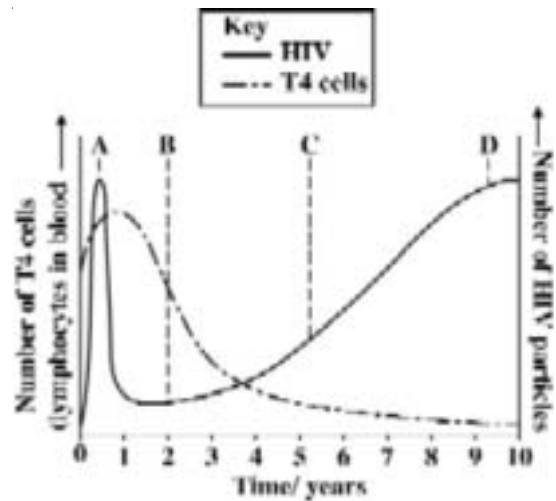

The patient is MOST likely to first show symptoms of AIDS at point

- (A) A
- (B) B
- (C) C
- (D) D

35. Which of the following is NOT a mode of transmission of the human immune deficiency virus (HIV)?

- (A) Intimate sexual contact
- (B) Contamination with infected blood
- (C) Mother's breast milk to her baby
- (D) Mosquito saliva and transfer of blood

36. Which of the following is the human body's first line of defence against invading pathogens?

- (A) The production of antibodies
- (B) The production of antigens
- (C) The ingestion of pathogens by B-lymphocytes
- (D) The ingestion of pathogens by phagocytes

37. Cells that divide and give rise to lymphocytes are called stem cells. In which of the following structures of the human body do these stem cells carry out their division?

- (A) Bone marrow
- (B) Spleen
- (C) Thymus
- (D) Lymph nodes

Item 38 refers to the following diagram which illustrates an antibody molecule.

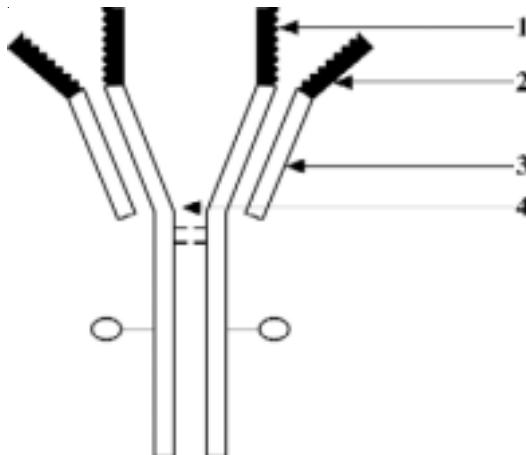

38. The two labels which represent the antigen binding site and the region which gives flexibility in binding to antigens are

- (A) 1 and 3
- (B) 2 and 3
- (C) 3 and 4
- (D) 1 and 4

39. Which of the following options best describes the type of immunity that results from taking an oral vaccine for polio?

- (A) Active natural immunity
- (B) Passive natural immunity
- (C) Active artificial immunity
- (D) Passive artificial immunity

40. A monoclonal antibody is

- (A) a small quantity of several antibodies
- (B) made by one particular type of B-lymphocyte
- (C) made by fusing a lymphocyte with a somatic cell
- (D) produced by T cells after exposure to one particular antigen

41. Long term exposure of the liver to high concentrations of alcohol eventually results in liver failure. This is due to the development of the disease called

- (A) Cirrhosis
- (B) Multiple sclerosis
- (C) Atherosclerosis
- (D) Arteriosclerosis

42. The table below shows the effects of three components of tobacco smoke (X, Y, Z) in humans.

X	Y	Z
Lung cancer	Constriction of arteries	Reduces the oxygen – carrying capacity of blood
Mucus secretion high	Release of adrenaline	Combines with haemoglobin

Which of the following correctly identifies X, Y and Z?

	X	Y	Z
(A)	Tar	Carbon monoxide	Nicotine
(B)	Tar	Nicotine	Carbon monoxide
(C)	Nicotine	Carbon monoxide	Tar
(D)	Carbon monoxide	Tar	Nicotine

43. What is the name of the enzyme used to produce sections of DNA from messenger RNA for use in genetic engineering?

- (A) DNA polymerase
- (B) Reverse transcriptase
- (C) Restriction endonuclease
- (D) RNA polymerase

44. Which of the following DNA molecules can be sectioned by using a restriction enzyme with a recognition site of AATT?

- (A) GCTTGCATAAGC  
CGAACGTATTCG
- (B) CATGGCATGGCA  
GTACCGTACCGA
- (C) AGTTCAGGTACC  
TCAAGTCCATGG
- (D) TACCGTTAAGCT  
ATGGCAATTCGA

Item 45 refers to the diagram below showing a map of a plasmid showing the positions of recognition sequences of two restriction enzymes.

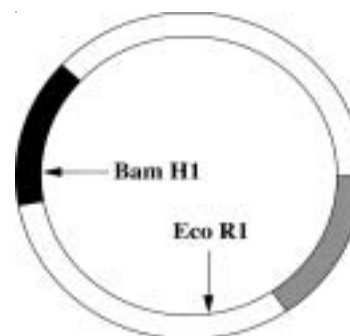

45. In an experiment to use this plasmid as a vector for the human insulin gene, for which of the following reasons would the genetic engineer choose the Bam location to cut this plasmid?

- (A) The insulin gene is not complementary to the Eco R1 restriction site
- (B) Bam H1 makes a staggered cut
- (C) To allow identification of the recombinant plasmid
- (D) The gene for tetracycline resistance is needed for the expression of the insulin gene.

**IF YOU FINISH BEFORE TIME IS CALLED, CHECK YOUR WORK ON THIS TEST.**

Listing of Form Section Data  
Caribbean Examinations Council (CXC)

Test: **CAPE BIOLOGY (U2)** (MC ITEMS) Form: **02207010-SPEC2017**

Version No: **1**

Item No.	Key	Syllabus Reference	Profile	Module
1	C	1.2	P1	M1
2	C	2.3	P1	M2
3	B	2.3	P1	M1
4	A	2.4	P1	M1
5	A	2.6	P2	M1
6	B	3.2	P2	M1
7	D	3.3	P1	M1
8	C	3.5	P1	M1
9	D	3.7	P2	M1
10	D	4.3	P2	M1
11	B	5.2	P2	M1
12	B	6.1	P2	M1
13	D	6.3	P1	M1
14	A	6.3	P2	M1
15	C	6.5	P1	M1
16	C	1.3	P1	M2
17	B	1.5	P1	M2
18	C	2.1	P2	M2
19	C	2.5	P2	M2
20	D	2.5	P2	M2
21	C	3.7	P1	M2
22	C	3.9	P1	M2
23	A	3.12	P2	M2
24	D	4.2	P1	M2
25	C	5.3	P2	M2
26	D	5.4	P1	M2
27	D	6.3	P1	M2
28	D	6.4	P1	M2
29	C	7.2	P2	M2
30	D	7.3	P2	M2

Listing of Form Section Data  
Caribbean Examinations Council (CXC)Test: **CAPE BIOLOGY (U2)** (MC ITEMS) Form: **02207010-SPEC2017**Version No: **1**

<b>Item No.</b>	<b>Key</b>	<b>Syllabus Reference</b>	<b>Profile</b>	<b>Module</b>
31	C	2.1	P1	M3
32	A	2.2	P1	M3
33	B	2.4	P2	M3
34	C	2.6	P2	M3
35	D	2.7	P1	M3
36	D	2.10	P1	M3
37	A	2.12	P1	M3
38	D	2.14	P2	M3
39	C	2.16	P2	M3
40	B	2.17	P2	M3
41	A	2.21	P1	M3
42	B	2.23	P2	M3
43	B	3.1	P1	M3
44	D	3.2	P2	M3
45	C	3.5	P2	M3

CARIBBEAN EXAMINATIONS COUNCIL

CARIBBEAN ADVANCED PROFICIENCY EXAMINATION®

“\*”Barcode Area”  
Front Page Bar Code

SPECIMEN PAPER

FILL IN ALL THE INFORMATION REQUESTED CLEARLY IN CAPITAL LETTERS.

TEST CODE 

0	2	2	0	7	0	2	0
---	---	---	---	---	---	---	---

SUBJECT BIOLOGY – UNIT 2 – Paper 02

PROFICIENCY ADVANCED

REGISTRATION NUMBER 

--	--	--	--	--	--	--	--	--	--

SCHOOL/CENTRE NUMBER  

--	--	--	--	--	--

NAME OF SCHOOL/CENTRE  

--

CANDIDATE’S FULL NAME (FIRST, MIDDLE, LAST)  

--

“\*”Barcode Area”  
Current Bar Code

DATE OF BIRTH 

D	D	M	M	Y	Y	Y	Y
---	---	---	---	---	---	---	---

SIGNATURE \_\_\_\_\_

“\*”Barcode Area”  
Sequential Bar Code



**DO NOT  
WRITE ON  
THIS PAGE**

SPEC 2017/02207020



TEST CODE 02207020

CARIBBEAN EXAMINATIONS COUNCIL

CARIBBEAN ADVANCED PROFICIENCY EXAMINATION®

BIOLOGY

UNIT 2 – Paper 02

*2 hours 30 minutes*

**READ THE FOLLOWING INSTRUCTIONS CAREFULLY.**

1. This paper consists of THREE questions. Answer ALL questions.
2. Write your answers in the spaces provided in this booklet.
3. Do NOT write in the margins.
4. You may use a silent, non-programmable calculator to answer questions.
5. You are advised to take some time to read through the paper and plan your answers.
6. If you need to rewrite any answer and there is not enough space to do so on the original page, you must use the extra lined page(s) provided at the back of this booklet. **Remember to draw a line through your original answer.**
7. **If you use the extra page(s), you MUST write the question number clearly in the box provided at the top of the extra page(s) and, where relevant, include the question part beside the answer.**

**DO NOT TURN THIS PAGE UNTIL YOU ARE TOLD TO DO SO.**

Copyright © 2017 Caribbean Examinations Council  
All rights reserved.

02207020/CAPE/SPEC 2017

“\*”Barcode Area”  
Sequential Bar Code

Module I

Answer ALL questions.

Write your answers in the spaces provided in this booklet.

1. (a) The graph in Figure 1 shows the effect of light intensity on photosynthesis at 0.1% carbon dioxide concentration in Elodea, an aquatic waterweed.

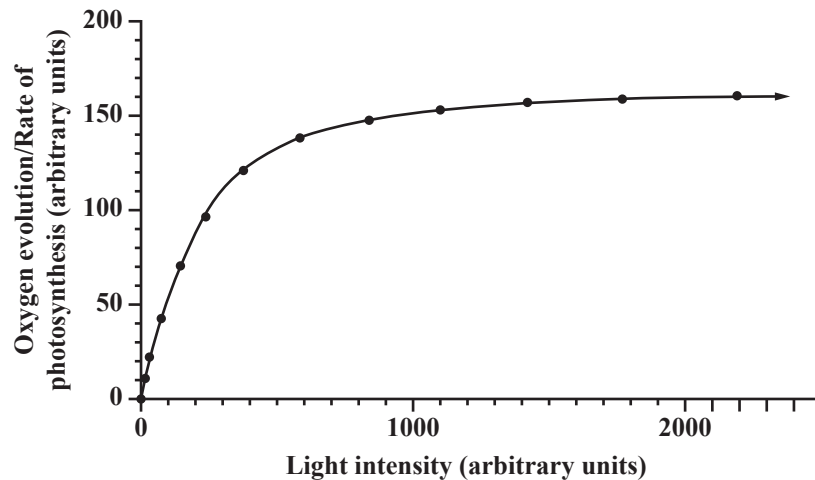

Figure 1. Graph showing the effect of light intensity on the rate of photosynthesis

Image modified from <http://www.cell.com/cms/attachment/533960/3680628/gr2.gif>

- (i) On the graph in Figure 1, draw the effect of light intensity on photosynthesis at 0.03% carbon dioxide concentration. [1 mark]
- (ii) A class carries out an experiment to study the effect of carbon dioxide concentration on the rate of photosynthesis. The students place a 5 cm length of *Nymphaea*, another waterweed, in varying concentrations of sodium bicarbonate in a lit area and record the number of bubbles that evolves from the plant in one minute. Table 1 shows the data obtained.

On the grid provided on page 5, plot a graph of the results in Table 1.

**Note:** Concentration of sodium hydrogen carbonate/concentration of carbon dioxide on the x- axis and rate of photosynthesis or average number of bubbles evolved per minute on the y-axis. [4 marks]

GO ON TO THE NEXT PAGE

**TABLE 1: DATA OBTAINED IN EXPERIMENT**

<b>Concentration of NaHCO<sub>3</sub> solution (%)</b>	<b>Average Number of Bubbles Evolved per Minute</b>
0.05	0
0.10	12
0.15	22
0.20	40
0.25	44
0.30	45

A large grid of graph paper, consisting of 20 columns and 20 rows of small squares, intended for recording experimental data.

GO ON TO THE NEXT PAGE

“\*”Barcode Area”\*”  
Sequential Bar Code

DO NOT WRITE IN THIS AREA

DO NOT WRITE IN THIS AREA

DO NOT WRITE IN THIS AREA

- (iii) During photosynthesis, light energy is converted into chemical energy. Outline TWO differences between the movement of energy and nutrients through an ecosystem.

.....

.....

.....

.....

.....

.....

.....

.....

.....

[4 marks]

DO NOT WRITE IN THIS AREA

“\*”Barcode Area”\*  
Sequential Bar Code

(b) Figure 2 shows a simplified nitrogen cycle.

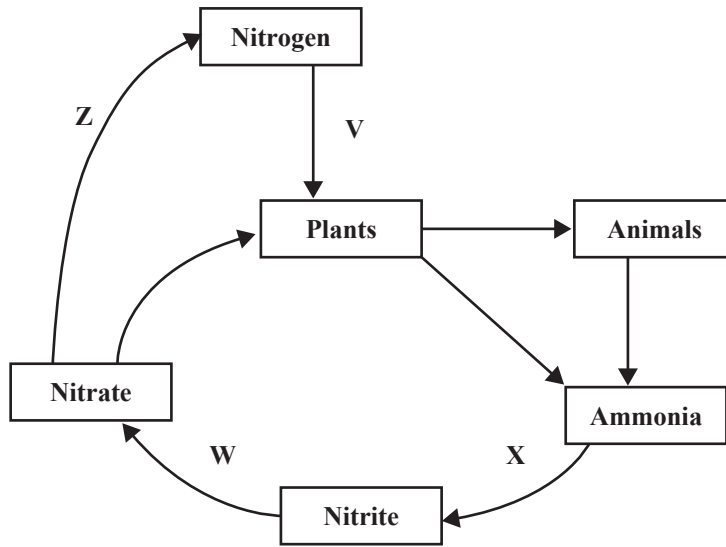

Figure 2. Simplified nitrogen cycle

<http://www.hyndland-sec.glasgow.sch.uk/websites/schsecHyndland/UserFiles/image/Biology.jpg>

(i) State the roles of Microorganisms V and Z in the nitrogen cycle.

V .....

.....

X .....

.....

[2 marks]

(ii) Many different relationships exist in ecosystems. With reference to named organisms, explain how parasitism differs from mutualism.

.....

.....

.....

.....

.....

[4 marks]

GO ON TO THE NEXT PAGE

- (c) The typical rainforest ecosystem is characterized by an enclosed canopy, high levels of rainfall and high species diversity. Given that an estimated 50 per cent of terrestrial biodiversity is found in rainforests, justify the need to conserve these rainforest ecosystems, and evaluate the use of protected forests areas as a method of conservation.

.....

.....

.....

.....

.....

.....

.....

.....

.....

.....

.....

.....

.....

.....

.....

.....

.....

.....

.....

.....

.....

.....

.....

.....

.....

DO NOT WRITE IN THIS AREA

GO ON TO THE NEXT PAGE

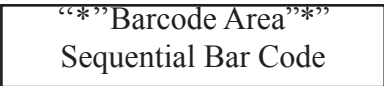

DO NOT WRITE IN THIS AREA

Handwriting practice area consisting of 25 horizontal dotted lines.

[15 marks]

**Total 30 marks**

GO ON TO THE NEXT PAGE

“\*”Barcode Area”  
Sequential Bar Code



Module 2

2. (a) Figure 3 is an image from a prepared slide of *Cucurbita* stem showing a cross section through phloem tissue highlighting a circular area within the image.

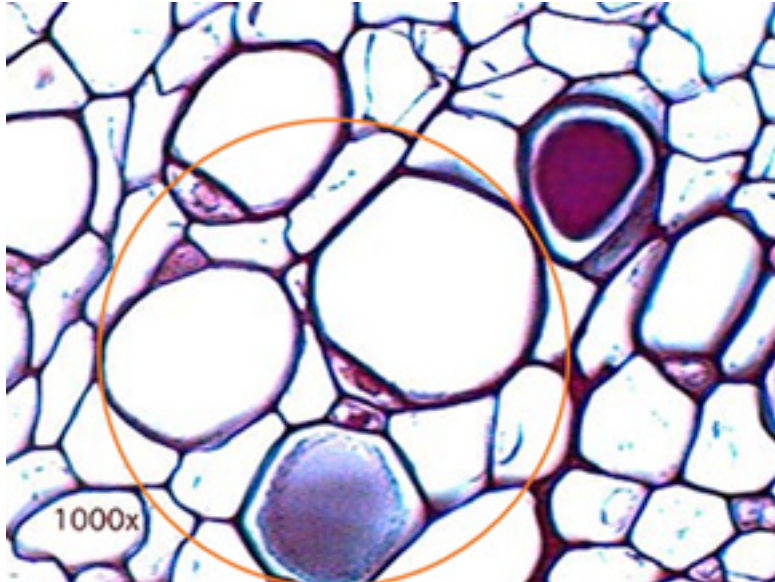
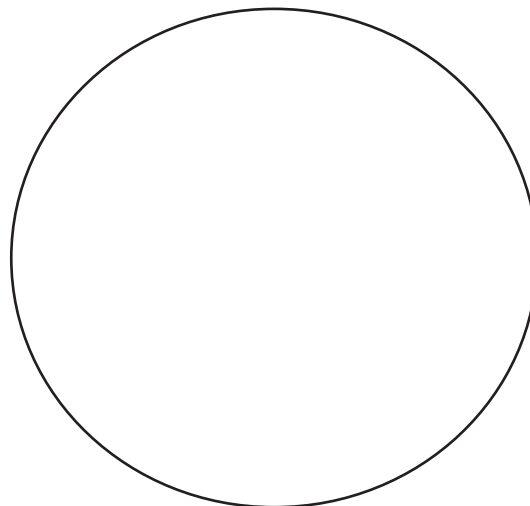

Figure 3. Cross section through phloem tissue

[http://botit.botany.wisc.edu/botany\\_130/anatomy/Cells\\_tissues/1000x.html](http://botit.botany.wisc.edu/botany_130/anatomy/Cells_tissues/1000x.html)

- (i) In the circular area provided below, make a detailed diagram of the circular area highlighted in Figure 3. Label THREE key features. [5 marks]



GO ON TO THE NEXT PAGE

- (ii) Explain the mechanism that drives translocation in plants.

.....

.....

.....

.....

.....

.....

.....

.....

.....

.....

.....

.....

.....

.....

.....

.....

.....

.....

.....

.....

.....

.....

[6 marks]

- (b) Unlike plants, the heart provides the driving force for the transport system in animals. In the space provided below, draw a labelled diagram of the mammalian heart. Include in your drawing the structure of the heart's chambers and valves.

[5 marks]

GO ON TO THE NEXT PAGE

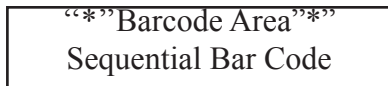

- (c) Discuss how the mammalian circulatory system is well adapted, structurally and functionally, to circulate blood and provide for the interchange of substances with the tissues.

.....

.....

.....

.....

.....

.....

.....

.....

.....

.....

.....

.....

.....

.....

.....

.....

.....

.....

.....

.....

.....

.....

.....

.....

“\*”Barcode Area”\*”  
Sequential Bar Code

DO NOT WRITE IN THIS AREA DO NOT WRITE IN THIS AREA DO NOT WRITE IN THIS AREA

DO NOT WRITE IN THIS AREA

Area with horizontal dotted lines for writing.

[14 marks]

Total 30 marks

GO ON TO THE NEXT PAGE

“\*” Barcode Area “\*”  
Sequential Bar Code

Module 3

- 3. (a) (i) State the name of the major carbohydrate stored in muscle tissue to provide a ready respiratory substrate.

[1 mark]

- (ii) Clarify the relationship between the presence of lactic acid in the muscle tissue and the oxygen debt.

[1 mark]

- (iii) Light exercise creates little demand on the rate of breathing and heart output but as exertion and duration increase, both breathing movements and heart output intensify. When the body is exercising at its maximum capacity, oxygen consumption is at its highest. This state is called VO max. It is measured as the volume of oxygen in cubic centimetres, used per kilogram of body mass per minute.

$$VO_2\text{max} = O_2 \text{ cm}^3\text{kg}^{-1}\text{minute}^{-1}$$

A sports laboratory is equipped with a stopwatch, a weighing scale, appropriate tubing and a gas analyser to measure oxygen consumption.

Explain the procedures and the calculations used to calculate the VO<sub>2</sub> max of an athlete.

[5 marks]

GO ON TO THE NEXT PAGE

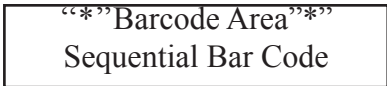

DO NOT WRITE IN THIS AREA

- (iv) A 35-year-old individual signed up for a 25-month endurance-training programme. Table 2 summarizes the physiological changes in the individual before, during and after the training period.

**TABLE 2: PHYSIOLOGICAL CHANGES IN THE INDIVIDUAL UNDERGOING ENDURANCE TRAINING**

	<b>Pre-training</b>	<b>15 months</b>	<b>25 months</b>
Body weight (kg)	79	73	78
Maximum ventilation (L/min)	184	200	198
Maximum cardiac output (L/min)	16.6	17.2	18.5
VO <sub>2</sub> max cm <sup>3</sup> kg <sup>-1</sup> minute <sup>-1</sup>	80	90	100
Stroke volume (ml)	100	60	119

Calculate the percentage increase in VO<sub>2</sub> max attained by the 35-year-old individual at the end of the 25-month period.

[1 mark]

(b) Physical exercise is not the only contributor to good health. The immune system of the body actively provides protection from various diseases.

(i) Compare the mode of action of plasma cells and phagocytes in fighting infections.

Plasma cells .....

.....  
.....  
.....  
.....  
.....  
.....  
.....  
.....  
.....  
.....

Phagocytes .....

.....  
.....  
.....  
.....  
.....  
.....  
.....  
.....  
.....

[4 marks]

DO NOT WRITE IN THIS AREA DO NOT WRITE IN THIS AREA DO NOT WRITE IN THIS AREA

GO ON TO THE NEXT PAGE

“\*”Barcode Area”\*”  
Sequential Bar Code

(ii) Discuss the ways in which the maturation process of B and T lymphocytes prepare them for their specific roles.

B-lymphocytes .....

.....

.....

.....

.....

.....

.....

.....

.....

.....

.....

.....

.....

.....

.....

T-lymphocytes .....

.....

.....

.....

.....

.....

.....

.....

.....

.....

.....

.....

.....

.....

.....

[6 marks]

DO NOT WRITE IN THIS AREA



- (c) Vaccination programmes (including diligent surveillance) are an important aspect of the work of the World Health Organization (WHO). By providing artificial active immunity, vaccinations have become an integral part of the various means by which Caribbean governments seek to protect their citizens from disease.

Explain the role of vaccination in providing immunity. Include in your response: definitions of 'active immunity' and 'vaccine'; give TWO examples of diseases vaccinated against; and comment on the successes and potential challenges of the use of vaccines.

.....

.....

.....

.....

.....

.....

.....

.....

.....

.....

.....

.....

.....

.....

.....

.....

.....

.....

.....

.....

.....

.....

.....

.....

.....

.....

GO ON TO THE NEXT PAGE

“\*”Barcode Area\*”  
Sequential Bar Code

DO NOT WRITE IN THIS AREA

DO NOT WRITE IN THIS AREA

Area with horizontal dotted lines for writing.

GO ON TO THE NEXT PAGE

“\*”Barcode Area”\*  
Sequential Bar Code

---

---

---

---

---

---

---

---

---

---

---

---

---

---

---

---

---

---

---

---

---

---

---

---

---

---

[12 marks]

Total 30 marks

**END OF TEST**

**IF YOU FINISH BEFORE TIME IS CALLED, CHECK YOUR WORK ON THIS TEST.**

“\*”Barcode Area\*”  
Sequential Bar Code

DO NOT WRITE IN THIS AREA



EXTRA SPACE

If you use this extra page, you **MUST** write the question number clearly in the box provided.

Question No.

.....

.....

.....

.....

.....

.....

.....

.....

.....

.....

.....

.....

.....

.....

.....

.....

.....

.....

.....

.....

.....

.....

DO NOT WRITE IN THIS AREA

**DO NOT  
WRITE ON  
THIS PAGE**

“\*”Barcode Area”  
Sequential Bar Code

**CANDIDATE'S RECEIPT**

**INSTRUCTIONS TO CANDIDATE:**

- 1. Fill in all the information requested clearly in capital letters.**

TEST CODE: 

0	2	2	0	7	0	2	0
---	---	---	---	---	---	---	---

SUBJECT: BIOLOGY – UNIT 2 – Paper 02

PROFICIENCY: ADVANCED

REGISTRATION NUMBER: 

--	--	--	--	--	--	--	--	--	--

FULL NAME: \_\_\_\_\_  
**(BLOCK LETTERS)**

Signature: \_\_\_\_\_

Date: \_\_\_\_\_

- 2. Ensure that this slip is detached by the Supervisor or Invigilator and given to you when you hand in this booklet.**
- 3. Keep it in a safe place until you have received your results.**

**INSTRUCTION TO SUPERVISOR/INVIGILATOR:**

Sign the declaration below, detach this slip and hand it to the candidate as his/her receipt for this booklet collected by you.

I hereby acknowledge receipt of the candidate's booklet for the examination stated above.

Signature: \_\_\_\_\_  
Supervisor/Invigilator

Date: \_\_\_\_\_

**DO NOT  
WRITE ON  
THIS PAGE**



## CANDIDATE'S RECEIPT

---

### INSTRUCTIONS TO CANDIDATE:

1. **Fill in all the information requested clearly in capital letters.**

TEST CODE: 

0	2	1	0	7	0	2	0
---	---	---	---	---	---	---	---

SUBJECT: BIOLOGY – UNIT 1 – Paper 02

PROFICIENCY: ADVANCED

REGISTRATION NUMBER: 

--	--	--	--	--	--	--	--	--	--

FULL NAME: \_\_\_\_\_  
**(BLOCK LETTERS)**

Signature: \_\_\_\_\_

Date: \_\_\_\_\_

2. **Ensure that this slip is detached by the Supervisor or Invigilator and given to you when you hand in this booklet.**
3. **Keep it in a safe place until you have received your results.**
- 

### INSTRUCTION TO SUPERVISOR/INVIGILATOR:

Sign the declaration below, detach this slip and hand it to the candidate as his/her receipt for this booklet collected by you.

I hereby acknowledge receipt of the candidate's booklet for the examination stated above.

Signature: \_\_\_\_\_  
Supervisor/Invigilator

Date: \_\_\_\_\_

C A R I B B E A N            E X A M I N A T I O N S            C O U N C I L

CARIBBEAN ADVANCED PROFICIENCY EXAMINATION®

BIOLOGY

UNIT 2 - Paper 02

KEYS AND MARK SCHEME

SPECIMEN PAPER

BIOLOGY

UNIT 2 - PAPER 02

KEY AND MARK SCHEME

Question 1 **Specific Objectives: 1.4, 3.1, 3.3, 3.4, 4.3, 4.5**

(i) Plot same shape, but lower plateau **[1 mark]**. **[1]**

(ii) Plotting graph

- Title
- Plot 4 of 5 points correctly to get the mark
- Axes correctly labelled with units
- Scale/Plot takes up at least half of the grid

**4 marks**

(iii) Differences between movement of energy and nutrients

1. Energy flows through and is converted from one form to another vs nutrients recycled.
2. Energy lost while flowing through ecosystem.
3. Unidirectional flow of energy (multidirectional for nutrient cycling)
4. Finite nature of nutrients vs. continuous supply of energy.
5. Nutrient cycles between abiotic and biotic components/ energy flow through organisms.

**2 marks each for any full comparison = 4 marks**  
**(1 mark for partial)**

**[4]**

(b) (i) V - Fixing nitrogen into the plants (*Rhizobium* bacteria)  
Z - Denitrifying bacteria converting nitrate to nitrogen gas  
**1 mark each** **[2]**

(ii) Parasitism vs mutualism

1. Named examples for each relationship **(2)**
2. Parasitism: indicate how host is harmed and how parasite benefits **(1)**
3. Mutualism: indicate how both organisms gain from the interaction **(1)**

**4 marks**

**[4]**

BIOLOGY

UNIT 2 - PAPER 02

KEY AND MARK SCHEME

Question 1 cont'd

(c) Rainforest

1. Poverty reduction/Livelihood (Income generating activity) provides employment for local people;
2. Foreign exchange earner - ecotourism site.
3. Food security.
4. Raw material for industrial processes - new medicines/materials could be found from organisms growing in the wild;
5. Recreation.
6. Sacred and spiritual value - cultural importance of species to indigenous groups.
7. Ecosystem value - depletion or degradation of natural resources and the threat to sustainable development.
  - conservation of components of life support systems;
  - conservation of endangered and threatened species;
  - disruption of ecosystems could lead to soil erosion/flooding /weather pattern changes;
  - disruption of water cycle/nutrient cycles;
8. Intrinsic value - right to exist; existence value beyond usefulness to humans.
9. Research and teaching
10. Aesthetical value

**Any 5 points well developed 2 mark each = 10 marks**

Protected forests

Definition of in situ or statement that protected areas involves in situ conservation

Positive

1. Requires no advanced technology
2. Protected areas can later be used as attractions to raise funds for further conservation efforts

Drawbacks

1. Difficult to monitor large areas of land
2. Can be expensive
3. Requires legislation
4. Large areas of protected lands could be used for other purposes

**1 mark for definition or recognition of protected areas as in situ method**

**Any two positive 2 marks**

**Any 2 drawbacks 2 marks**

**[15 marks]**

**Total 30 marks**

BIOLOGY

UNIT 2 - PAPER 02

KEY AND MARK SCHEME

**Question 2 Specific Objectives: 2.1, 2.3, 3.1, 3.3**

(a) (i)

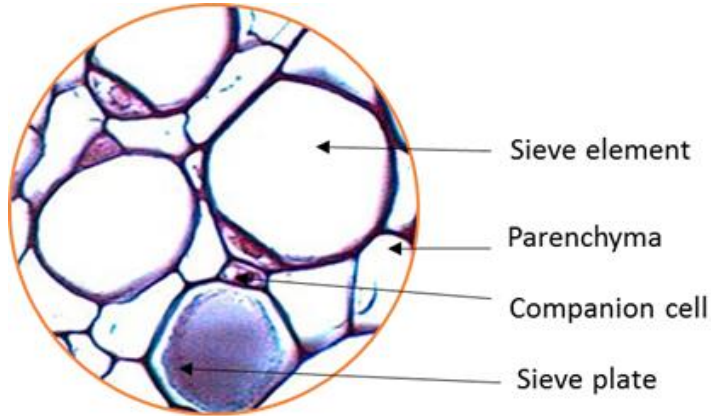

- Diagram representative - 1 mark
- Acceptable proportions - 1 mark
- Any three correct labels - 1 mark each

[5 marks]

(ii) Translocation in plants

1. Phloem loading at source
2. Movement due to pressure gradient
3. Unloading at sink

**For each point with full explanation - 2 marks**  
**(Partial explanation - 1 mark)**

[6 marks]

BIOLOGY

UNIT 2 - PAPER 02

KEY AND MARK SCHEME

Question 2 cont'd

(b) Drawing of the heart

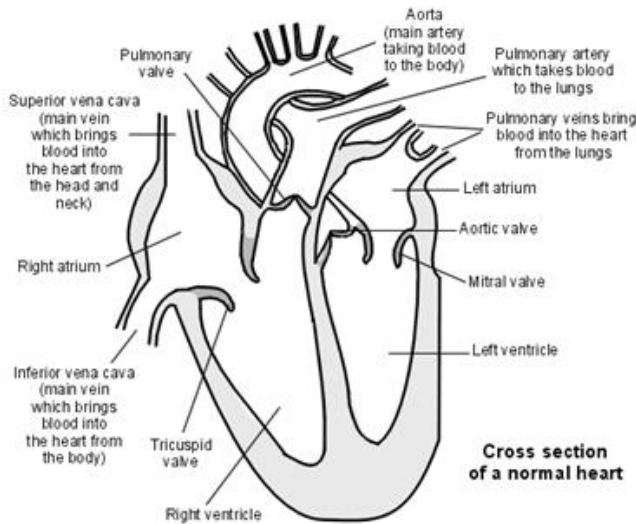

<https://userscontent2.emaze.com/images/688d237b-f946-4ac5-9217-eafa0d068781/82295c69-0bd1-4aae-82bb-c82dad81f489.qif>

- Appropriate diagram - **1 mark**
- All chambers correctly labelled - **2 marks**  
(1-2 errors or omissions - 1 mark)
- All valves correctly labelled - **2 marks**  
(1-2 errors or omissions - 1 mark)

**[5 marks]**

(c) Circulation

Heart adaptations

1. Heart is a muscular pump that forces blood through the system; cardiac muscle is resistant to fatigue (cells have large numbers of mitochondria)
2. Double circulatory system (pulmonary and systemic); ensures that oxygenated blood is delivered to the systemic system at high pressure/lower pressure is needed in the pulmonary system
3. Presence of valves: atrio-ventricular and semi-lunar valves - allow one way circulation
4. Stimulus to contract comes from within heart (myogenic) -SAN, AVN, Purkyne fibres - ensures that the ventricles contract after the atria and from base upwards

**Any 3 points well discussed - 2 marks each = 6 marks**  
**(incomplete discussion - 1 mark each)**

BIOLOGY

UNIT 2 - PAPER 02

KEY AND MARK SCHEME

Question 2 cont'd

Adaptations of blood vessels (7-8 marks)

- Arteries have thick walls with large amount of elastic tissue - allows walls to withstand high pressure of blood from heart
- Small arteries and arterioles have large amount of smooth muscle in walls - allows constriction, which can divert blood from one area to another
- Smooth endothelium (inner lining) in blood vessels - allows free blood flow (lower resistance); reduces the risk of blood clots
- Veins have relatively large lumen (low resistance) and valves (not present in arteries) - valves allow one-way flow of blood to the heart - necessary due to the low pressure of blood in veins
- Capillaries have very thin wall (one cell thick and flattened) and tiny lumen diameter - allows rapid transfer of substances by diffusion between blood and tissues / tiny lumen brings blood close to tissues
- All organs have extensive network of capillaries - ensures that interchange of substances occurs in all tissues.

**Any 4 points well discussed - 2 marks each = 8 marks  
(incomplete discussion - 1 mark each)**

**14 marks**

**Total 30 marks**

BIOLOGY

UNIT 2 - PAPER 02

KEY AND MARK SCHEME

**Question 3 Specific Objectives: 3.3, 2.1, 2.2, 2.4, 2.5, 2.9, 2.10**

- (a) (i) Carbohydrate - glycogen **1 mark** [1]
- (ii) The oxygen debt is the deficit in oxygen required to oxidize the accumulated lactic acid to pyruvate. **1 mark** [1]

(iii) Procedure for calculating  $VO_2\text{max}$

1. Determine the weight, in kilograms of the athlete.
2. Exercise the athlete to maximum exertion.
3. Over a 60-second period, measure the oxygen consumption in  $\text{cm}^3$  (or any acceptable answer to achieve the  $O_2$  consumption in 1 minute).
4. Divide the oxygen consumption in one minute by the kilograms to find the  $O_2$  used per kilogram.
5. That gives the volume of  $O_2$  in  $\text{cm}^3$  per  $\text{kilogram}^{-1}$  per  $\text{minute}^{-1}$ .

**5 marks**

**[5]**

(iv) Calculating  $VO_2\text{max}$

$$[(100-80)/80] * 100 = 25\%$$

**Correct answer, even without working, 1 mark**

**[1]**

(b) (i) Plasma cells

1. Formed from B-cells (by differentiation).
2. Secrete/synthesize antibodies (against specific antigens).
3. Each type of plasma cell produces a single type of antibody.
4. The antibody agglutinates/traps/inactivates the antigen.
5. They are "effector" cells - carry out the "end reaction" of the immune response.
6. They increase in number rapidly during an infection, and decrease after the antigen is controlled.

Phagocytes

1. Are amoeboid cells produced in the bone marrow and they circulate in the blood.
2. They move rapidly to the site of an infection.
3. They can squeeze through capillary walls and directly invade the infection site.
4. They engulf antigens (large proteins/bacteria etc.  $< 250 \text{ nm}$ ).
5. They digest and kill the pathogens in a cellular vesicle.
6. They remove alien/foreign molecules which may cause harm to that organ, e.g. lung, liver.

**Any 2 comparisons = 4 marks**

**[4]**



BIOLOGY

UNIT 2 - PAPER 02

KEY AND MARK SCHEME

Question 3 cont'd

(ii) B-lymphocytes

1. B-cells originate in bone marrow from stem cells by mitosis.
2. Mature in bone marrow.
3. Genes are rearranged to give many (10 million) varying protein codes.
4. These variants code for different antibody surface receptors.
5. Each B-cell is programmed to express just one type of surface receptor during maturation.
6. The range of B-cells will have an immense number of different receptors.
7. Hence, there will be a B-cell with receptor for any/every antigen.

**5 points - 3 marks**

**3-4 points - 2 marks**

**1-2 points - 1 mark**

**[3]**

T-lymphocytes

1. Form in bone marrow from stem cells by mitosis.
2. Migrate to thymus.
3. Differentiate genotype to form thousands of variants.
4. Variant genes code for specific surface receptors.
5. T-cells have a wide range of individual surface receptors.
6. T-cells have the body's own antigens presented to them by MHC.
7. If a T-cell binds with and reacts with one of the body's own protein it is killed.
8. This prevents having T-cells that attack the body's own cells, i.e. an autoimmune attack in the body by its own.

**5 points - 3 marks**

**3-4 points - 2 marks**

**1-2 points - 1 mark**

**[3]**

(c) Active immunity

1. The immunity that results from the production of antibodies by the immune system in response to the presence of an antigen.
2. The result of the response of the body to an antigen/infection, which has long-term effects.
3. Immunity in an organism resulting from its own production of antibodies or lymphocytes.

**Any one = 1 mark**

BIOLOGY

UNIT 2 - PAPER 02

KEY AND MARK SCHEME

Question 3 cont'd

Vaccine

1. A preparation containing antigenic material and used to increase immunity.
2. A substance used to stimulate the production of antibodies and provide immunity against one or several diseases.
3. A preparation of killed microorganisms, living attenuated organisms, or living fully virulent organisms that is administered to produce or artificially increase immunity to a particular disease.

**Any one = 1 mark**

Examples

Polio, measles, mumps, rubella, Tuberculosis, Small Pox, influenza, chicken pox, shingles, tetanus

**Any two correct examples, including any not listed = 2 marks**

Successes

1. Vaccines are among the most effective means of preventing disease, disability and death in infants, children, adolescents and adults.
2. Diseases can be eliminated locally without global eradication of the causative microorganism. E.g. measles which had been eliminated in 4 of 6 WHO regions
3. Caribbean territories have made great strides in reducing and eliminating morbidity and mortality caused by Vaccine Preventable Diseases.
4. Has led to the eradication of smallpox
5. Some vaccines are highly effective and give lifetime protection
6. There is an excellent safety record with vaccines. Less reactogenic vaccines have been developed.
7. Vaccination programmes are cheaper than providing therapeutic drugs. This, along with reduced morbidity and mortality, translates into long-term savings and possible economic growth.
8. Reduces the need for antibiotics, thus helps to prevent the development of antibiotic resistance.
9. "Herd protection" of the unvaccinated occurs when a sufficient proportion of the group is immune.
10. Unless an environmental reservoir exists, an eradicated pathogen cannot re-emerge, unless inadvertently or purposely reintroduced by humans

BIOLOGY

UNIT 2 - PAPER 02

KEY AND MARK SCHEME

Question 3 cont'd

11. Protection against related diseases. Vaccines will also protect against diseases related to the targeted disease. For example, measles vaccination protects against multiple complications such as dysentery and bacterial pneumonia.
12. Cancer prevention. Reduction of the incidence of cervical cancer is expected with the use of HPV vaccines.
13. Safer travel and mobility between territories

**Any 4 points = 4 marks**

Challenges

1. Eradication requires high levels of population immunity in all regions of the world over a prolonged period with adequate surveillance in place.
2. Some individuals do not respond well or do not respond at all to vaccinations. i.e. the vaccine is ineffective in them.
3. There are no vaccines to the common cold due to antigenic variation (multiple strains).
4. The influenza virus mutates regularly to give different antigens. Therefore, there have to be constant changes to the vaccine.
5. Anti-vaccination campaigns. Usually associated with the perception that the MMR vaccine causes autism.
6. Fear of needles
7. The costs associated with setting up vaccination programmes.
8. Difficulty in reaching remote areas
9. Lack of proper surveillance to accompany the vaccination efforts.
10. Globalization and increased travel

**Any 4 points = 4 marks**

**[12]**

**Total 30 marks**

CARIBBEAN EXAMINATIONS COUNCIL

CARIBBEAN ADVANCED PROFICIENCY EXAMINATION®

“\*”Barcode Area”\*”  
Front Page Bar Code

SPECIMEN PAPER

FILL IN ALL THE INFORMATION REQUESTED CLEARLY IN CAPITAL LETTERS.

TEST CODE 

0	2	2	0	7	0	3	2
---	---	---	---	---	---	---	---

SUBJECT BIOLOGY – UNIT 2 – Paper 032

PROFICIENCY ADVANCED

REGISTRATION NUMBER 

--	--	--	--	--	--	--	--	--	--

SCHOOL/CENTRE NUMBER  

--	--	--	--	--	--

NAME OF SCHOOL/CENTRE  

--

CANDIDATE’S FULL NAME (FIRST, MIDDLE, LAST)  

--

DATE OF BIRTH 

D	D	M	M	Y	Y	Y	Y
---	---	---	---	---	---	---	---

SIGNATURE \_\_\_\_\_

“\*”Barcode Area”\*”  
Current Bar Code

“\*”Barcode Area”\*”  
Sequential Bar Code

**DO NOT  
WRITE ON  
THIS PAGE**

SPEC 2017/02207032



TEST CODE 02207032

CARIBBEAN EXAMINATIONS COUNCIL

CARIBBEAN ADVANCED PROFICIENCY EXAMINATION®

BIOLOGY - SPECIMEN PAPER

UNIT 2 – Paper 032

ALTERNATIVE TO SCHOOL-BASED ASSESSMENT

*2 hours*

**READ THE FOLLOWING INSTRUCTIONS CAREFULLY.**

1. This paper consists of THREE questions. Answer ALL questions.
2. Write your answers in the spaces provided in this booklet.
3. Do NOT write in the margins.
4. You may use a silent, non-programmable calculator to answer questions.
5. You are advised to take some time to read through the paper and plan your answers.
6. If you need to rewrite any answer and there is not enough space to do so on the original page, you must use the extra lined page(s) provided at the back of this booklet. **Remember to draw a line through your original answer.**
7. **If you use the extra page(s), you MUST write the question number clearly in the box provided at the top of the extra page(s) and, where relevant, include the question part beside the answer.**

**DO NOT TURN THIS PAGE UNTIL YOU ARE TOLD TO DO SO.**

---

Copyright © 2017 Caribbean Examinations Council  
All rights reserved.

02207032/CAPE/SPEC 2017

“\*”Barcode Area”\*”  
Sequential Bar Code

**Answer ALL questions.**

**Write your answers in the spaces provided in this booklet.**

**Please begin Question 1 FIRST.**

You are provided with two specimens, A and B.

1. (a) Make a labelled drawing of Specimen A.

**[6 marks]**

(b) (i) Investigation of stomatal density of Specimen B.

Procedure:

- Spread a thin layer of nail varnish over the lower surface of Specimen B
- Allow to dry
- Peel off the thin replica with a fine forceps.
- Lay it on a slide and add a cover slip (it may be mounted in water if you choose).
- Count the number of stomata in a given field of view and repeat THREE times in different areas.
- Obtain a mean value.
- Record your results in the table below.

Count 1	Count 2	Count 3	$\bar{x}$

- Calculate the number of stomata per cm<sup>2</sup>. Show your working.

Stomatal density .....

.....  
[5 marks]

GO ON TO THE NEXT PAGE



- (ii) Would you expect stomatal density to be the same on the upper surface of Specimen B? Explain your answer.

.....

.....

.....

.....

.....

.....

.....

[2 marks]

“\*”Barcode Area”\*”  
Sequential Bar Code

DO NOT WRITE IN THIS AREA

(c) Figure 1 shows a transverse section of a leaf.

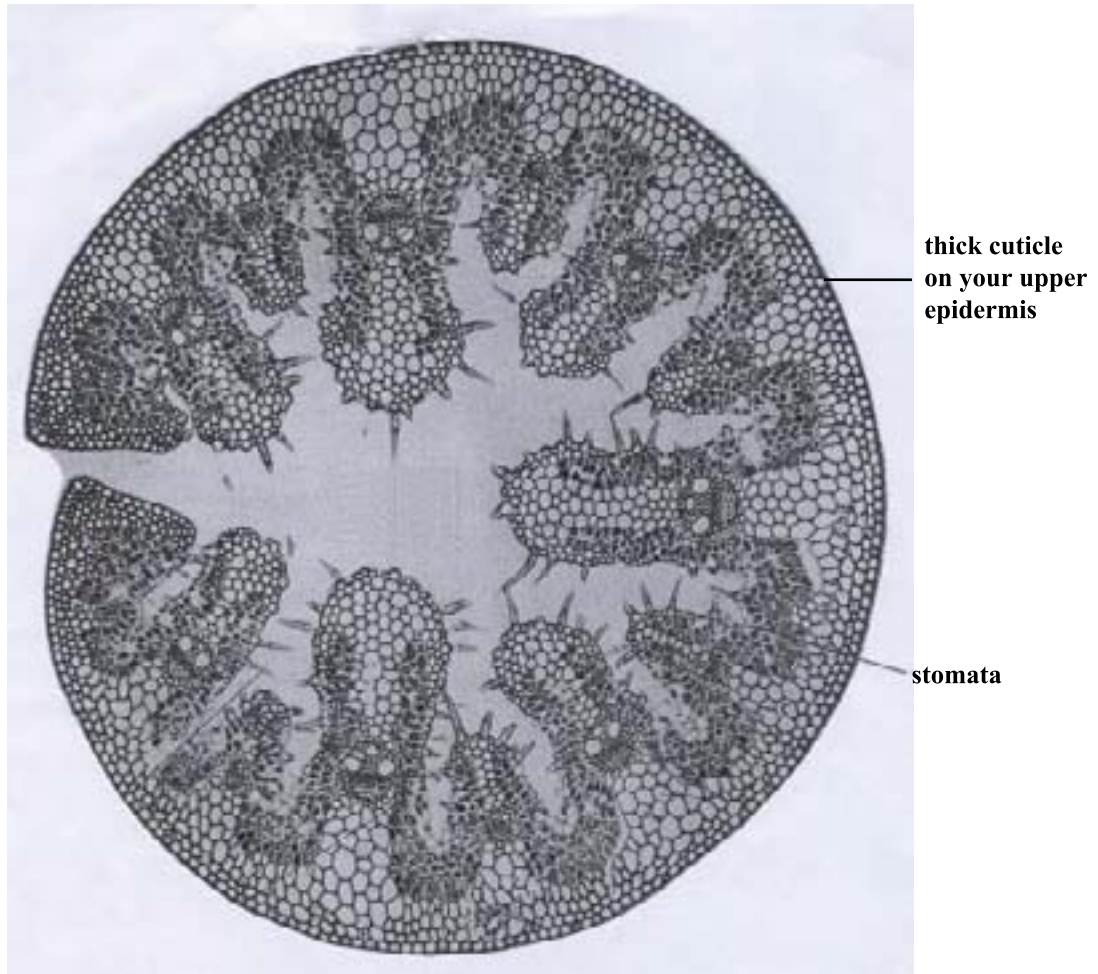

List, with explanations, THREE features of the leaf shown in Figure 1 that show how the plant is adapted to a dry environment.

.....

.....

.....

.....

.....

.....

.....

.....

[3 marks]

**Total 15 marks**

GO ON TO THE NEXT PAGE

2. You are provided with the following apparatus and materials.

- Water bath
- Thermometer
- Elodea shoot
- Test tubes
- Sodium hydrogen carbonate solution
- Apparatus for measuring gas
- Meter rule
- 100 W lamp

Use the apparatus above to plan and design an experiment to test the following observation:

**Water plants evolve large volumes of gas when placed in a well illuminated area.**

(a) Suggest a suitable hypothesis based on the observation given.

.....

.....

.....

.....

.....

[2 marks]

(b) Write a suitable aim based on the hypothesis.

.....

.....

.....

.....

[1 mark]

GO ON TO THE NEXT PAGE

- (c) Design an experimental procedure capable of testing the aim outlined in (b) on **page 8**.

.....

.....

.....

.....

.....

.....

.....

.....

.....

.....

.....

.....

.....

.....

.....

.....

.....

.....

.....

.....

.....

.....

.....

.....

- (d) (i) What results would be expected from the investigation? **[6 marks]**

.....

.....

.....

.....

**[1 mark]**

GO ON TO THE NEXT PAGE

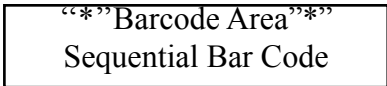

(ii) Design an appropriate table to show how the results could be presented.

[4 marks]

(e) What limitation could be expected from an experiment of this nature?

.....

.....

.....

.....

[1 mark]

**Total 15 marks**

GO ON TO THE NEXT PAGE

DO NOT WRITE IN THIS AREA

3. Table 1 contains data on the typical birth-weights of babies over a period of 10 years. The mortality of babies, in relation to birth-weight is shown in Table 2.

**TABLE 1. TYPICAL BIRTH-WEIGHT (AS A PERCENTAGE) OVER 10 YEARS**

Birth-weight of babies (lbs)	% of babies	
0-1 1-2 2-3 3-4	} pre-drawn on histogram	
4-5		2
5-6		9
6-7		18
7-8	14	
8-9	5	
9-10 10-11 11-12	} pre-drawn on histogram	

**TABLE 2: PERCENTAGE MORTALITY OF BABIES IN RELATION TO BIRTH-WEIGHT**

Birth-weight of babies (lbs)	% mortality
3	60
4	30
5	7
6	2.5
7	1.5
8	2
9	3
10	6
11	15

Use the data in Tables 1 and 2 above to answer questions (a) (i) and (ii).

- (a) (i) On the grid provided in Figure 2 on page 12, complete the **histogram** of the typical birth-weight of babies over a 10-year period. (**Note** that portions of this histogram have been pre-drawn).
- (ii) Also on Figure 2, construct a **graph** of the percentage mortality of babies in relation to birth-weight. (Use a best-fit line).

[5 marks]

GO ON TO THE NEXT PAGE

BIRTH-WEIGHT/ % MORTALITY

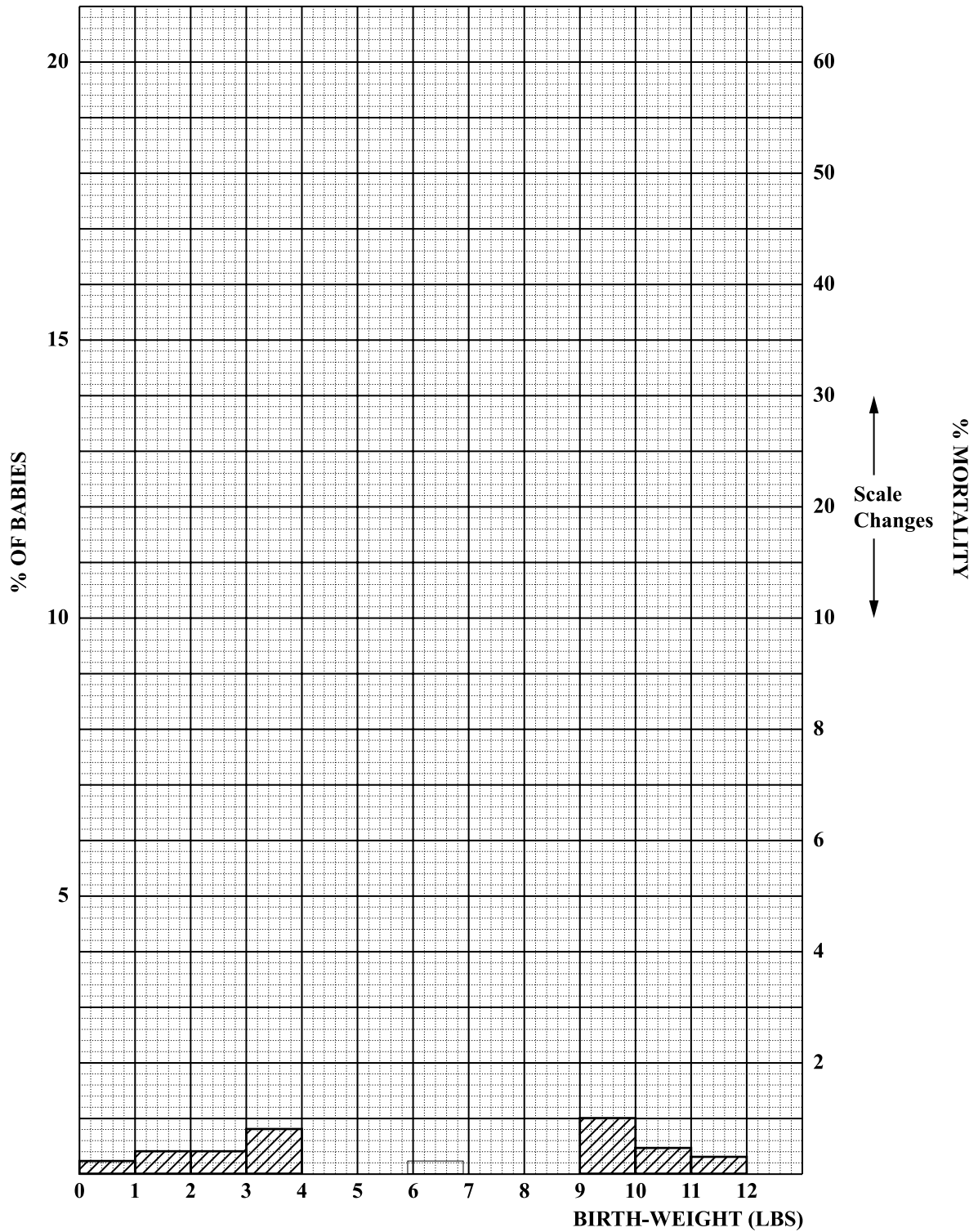

DO NOT WRITE IN THIS AREA DO NOT WRITE IN THIS AREA DO NOT WRITE IN THIS AREA

GO ON TO THE NEXT PAGE

02207032/CAPE/SPEC 2017

“\*”Barcode Area”  
Sequential Bar Code

- (b) Using quantitative information from the graphs drawn on **page 12**, comment on the effect of birth-weight on percentage mortality.

.....

.....

.....

.....

.....

.....

.....

.....

[3 marks]

- (c) State ONE effect the observations made in (b) have on the gene pool controlling the birth-weight of the foetus.

.....

.....

[1 mark]

- (d) In terms of Natural Selection, what type of selection is operative in (c)?

.....

[1 mark]

- (e) Two special groups, the Masai and the Pygmies have different anthropomorphic measurements. The Masai people are typically over six feet in height, white and tall. Pygmy people rarely exceed 4' 8" in height.

Draw TWO additional graphs on Figure 2 as follows:

- (i) A graph line to represent the expected percentage mortality of babies in relation to birth-weight born to Masai.
- (ii) A graph line to represent the expected percentage mortality of babies in relation to birth-weight born to Pygmies.

[2 marks]

GO ON TO THE NEXT PAGE

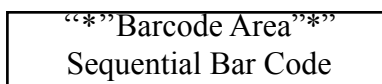



- (f) Pig litters range in size from about three to eighteen piglets per litter. The average number of piglets surviving in litters was determined three and six weeks after birth. Figure 3 shows the results of the investigation.

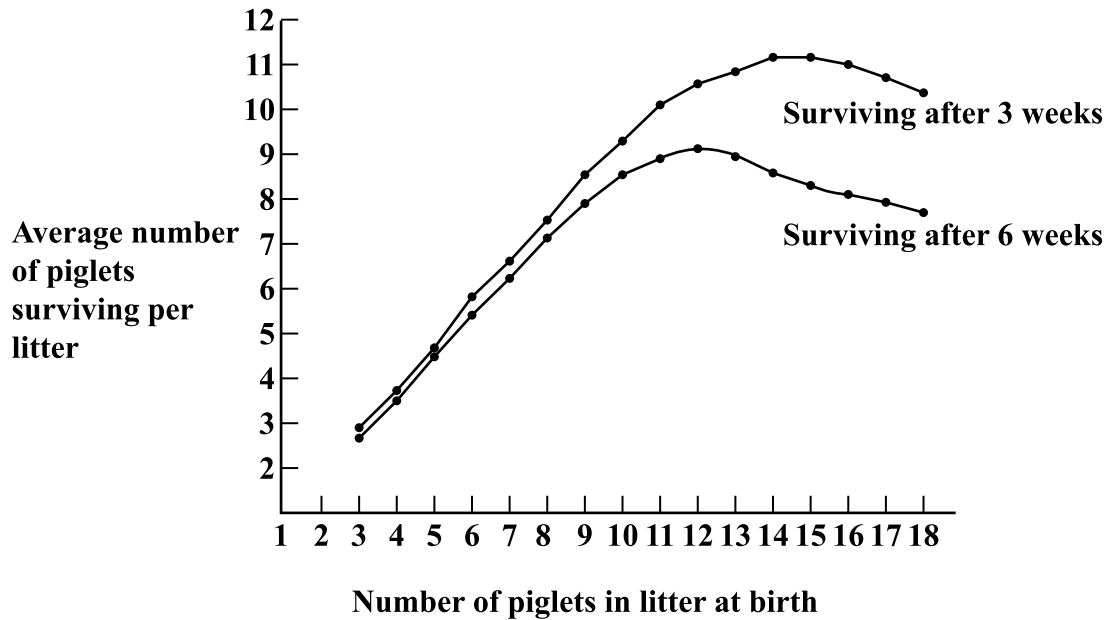

Figure 3. Litter size and piglet survival

*Adapted from Problems in Animal Physiology, John Murray. 50, Albemarle St. London WLX 4BD, M.K. Sands, 1975.*

- (i) Complete Table 3 to show the difference in survival of piglets in the two litters.

TABLE 3. LITTER SIZE AND SURVIVAL IN PIGS

Number of Piglets in Litter at Birth	Average Number of Piglets Surviving After 3 weeks	Average Number of Piglets Surviving After 6 weeks
3		
9		
15		

[3 marks]

GO ON TO THE NEXT PAGE

- (ii) Use the data from Figure 3 to suggest, with a reason, the optimum litter size for maximum survival.

.....

.....

.....

.....

[2 marks]

**Total 15 marks**

**END OF TEST**

**IF YOU FINISH BEFORE TIME IS CALLED, CHECK YOUR WORK ON THIS TEST.**

DO NOT WRITE IN THIS AREA





### EXTRA SPACE

If you use this extra page, you MUST write the question number clearly in the box provided.

Question No.

.....  
.....  
.....  
.....  
.....  
.....  
.....  
.....  
.....  
.....  
.....  
.....  
.....  
.....  
.....  
.....  
.....  
.....  
.....  
.....  
.....  
.....  
.....  
.....  
.....  
.....  
.....  
.....

DO NOT WRITE IN THIS AREA

“*” Barcode Area “*” Sequential Bar Code
---

**DO NOT  
WRITE ON  
THIS PAGE**

## CANDIDATE'S RECEIPT

---

### INSTRUCTIONS TO CANDIDATE:

1. **Fill in all the information requested clearly in capital letters.**

TEST CODE: 

0	2	2	0	7	0	3	2
---	---	---	---	---	---	---	---

SUBJECT: BIOLOGY – UNIT 2 – Paper 032

PROFICIENCY: ADVANCED

REGISTRATION NUMBER: 

--	--	--	--	--	--	--	--	--	--

FULL NAME: \_\_\_\_\_  
**(BLOCK LETTERS)**

Signature: \_\_\_\_\_

Date: \_\_\_\_\_

2. **Ensure that this slip is detached by the Supervisor or Invigilator and given to you when you hand in this booklet.**
3. **Keep it in a safe place until you have received your results.**
- 

### INSTRUCTION TO SUPERVISOR/INVIGILATOR:

Sign the declaration below, detach this slip and hand it to the candidate as his/her receipt for this booklet collected by you.

I hereby acknowledge receipt of the candidate's booklet for the examination stated above.

Signature: \_\_\_\_\_  
Supervisor/Invigilator

Date: \_\_\_\_\_

02207032/CAPE/SPEC/KMS 2017

C A R I B B E A N            E X A M I N A T I O N S            C O U N C I L

CARIBBEAN ADVANCED PROFICIENCY EXAMINATION®

BIOLOGY

UNIT 2 - Paper 032

KEYS AND MARK SCHEME

SPECIMEN PAPER



CAPE BIOLOGY

UNIT 2 - PAPER 032

MARK SCHEME

**Question 1.**

(a) Specimen A: slide of lower epidermis of a leaf (whole mount)

- Clear accurate line representation of specimen
- Clean continuous lines of even thickness
- Use of label lines that do not cross
- Accurate labelling
- Features correctly proportioned
- Magnification given
- Title given

(b) (i) Specimen B: dicotyledonous leaf

- Mean correctly calculated
- Calculation of stomatal density
- Use of appropriate units

(ii) • No  
 • Because it is a dicotyledonous leaf

- (c)
- Leaf rolled - to reduce transpiration rate
  - Stomata on lower epidermis not exposed to dry atmosphere
  - Presence of hairs trap H<sub>2</sub>O - creating humid environment
  - Humid conditions in interior result in reduced transpiration.
  - Thick cuticle to reduce water loss across epidermis

**Any point - 1 mark up to a maximum of 3 marks**

UK	XS
	5
	2
	2
	1
1	
1	
3	
5	10

CAPE BIOLOGY

UNIT 2 - PAPER 032

MARK SCHEME

**Specific Objectives: 1.5, 1.6 - Module 2**

**Question 2.**

- (a) • Mention of light being necessary for the process of photosynthesis, therefore in well illuminated areas, large amounts of oxygen will be released.
- Increase in availability of light increases the rate of light dependent and hence light independent stages.

**Statement relating directly to observation - 1 mark**

**Testable hypothesis - 1 mark**

- (b) • To investigate the effect of light intensity on the rate of photosynthesis.

**Suitable and related to hypothesis - 1 mark**

- (c) • Suitable and logical sequence (can be enhanced with diagram).
- Controls included, i.e. parallel experiment set up with light source placed at one constant distance throughout experiment.
- Attempts to control conditions
  - use of NaHCO<sub>3</sub> to ensure sufficient CO<sub>2</sub>
  - use of thermometer to check for changes in temperature. Replace water if change noted.
- Duration of investigation.
  - length of time elapse before volume of gas is measured for each light intensity.
- Number of trials stated - to ensure reproductively of experiment.

**Present tense MUST be used. - 1 mark**

UK	XS
	2
	1

CAPE BIOLOGY

UNIT 2 - PAPER 032

MARK SCHEME

	6
--	---

**1 mark for each point correctly done**

**1 mark x 5 points - 5 marks**

**Past tense - 1 mark**

UK	XS
----	----

**Question 2. (continued)**

- (d) (i) As distance from lamp decreases/increases THEN volume of gas SHOULD increase/decrease.

**Future tense MUST be used - 1 mark**

**Future tense NOT used - 0 mark**

	1
	4
	1

- (ii) • Table must have title.
- 3 columns, distance from lamp, light intensity, volume of oxygen.
- Units must be shown, at least for lamp distance and volume of oxygen.
- Distances from lamp must be shown in increasing or decreasing order.

Example of table showing the effect of light intensity on rate of photosynthesis.

Distance of Lamp cm	Light Intensity	Volume of O <sub>2</sub> cm
80		
40		
20		
10		
5		

**1 mark for EACH point - 4 marks**

- (e) • Amount of light in room, not given off from lamp can affect results when distance from lamp is great.

**Limitation stated and explained - 1 mark**

CAPE BIOLOGY

UNIT 2 - PAPER 032

MARK SCHEME

-	15
---	----

Specific Objectives: 1.6 - Module 1

Question 3.

(a)

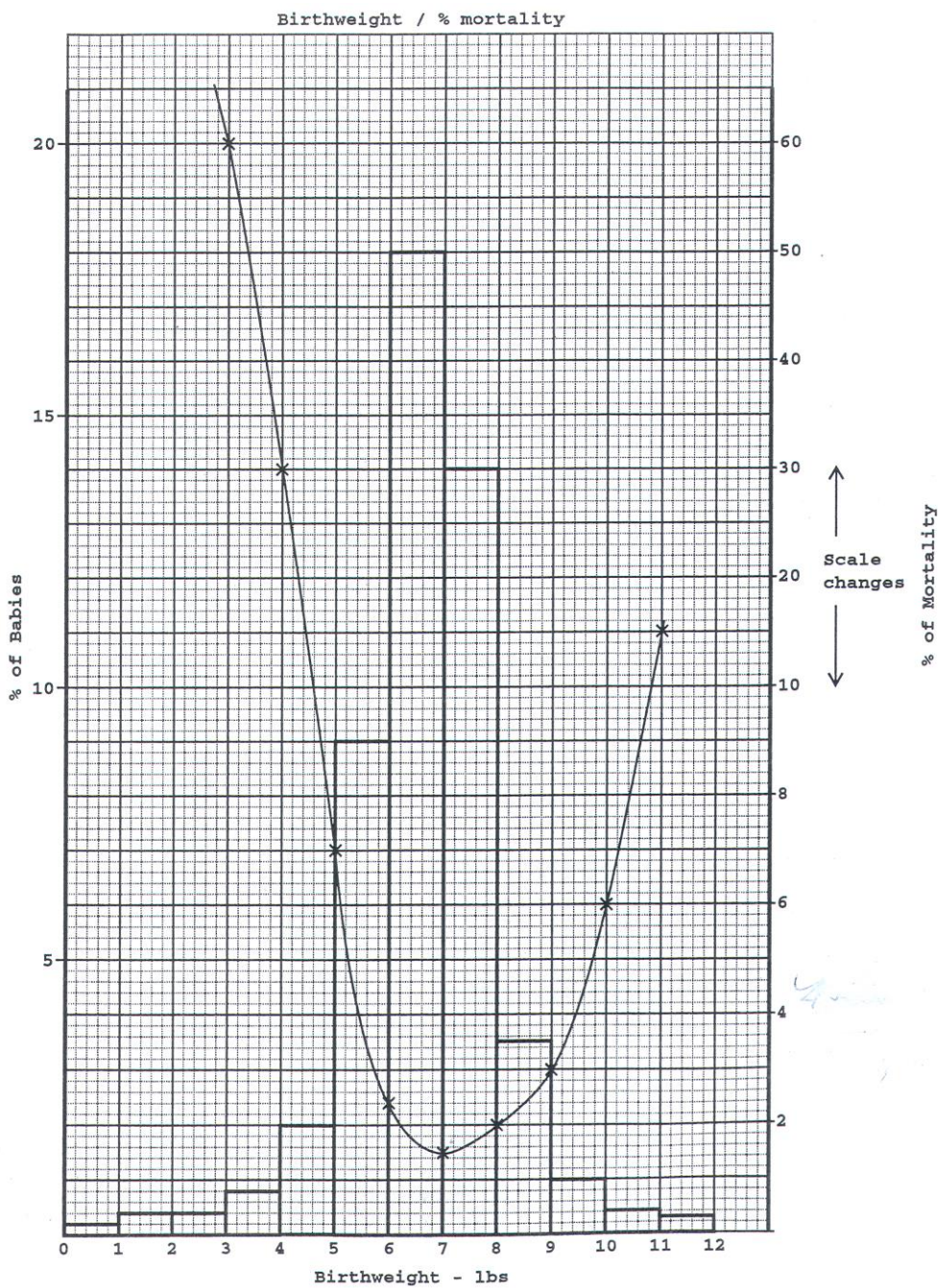

Histogram: 4 - 5 bars well drawn - 3 marks  
 3 bars well drawn - 2 marks

UK	XS

CAPE BIOLOGY

UNIT 2 - PAPER 032

MARK SCHEME

**Graph: All points correct, well drawn - 2 marks  
1 error or poorly drawn - 1 mark**

**4 marks from Histogram + 2 marks from graph = 6 marks**

	<b>5</b>
--	----------

**Question 3. (continued)**

- (b)
- Babies of 6 - 7 lbs (which constitute 18% of births) have the lowest mortality (2.5 and 1.5%).
  - Babies of 3 - 4 lbs have the highest percentage mortality of 90%.
  - Babies of 11 lbs also show high % mortality of 15%.

**3 correct points, using data from the table - 3 marks**

- (c)
- The next generation would receive more genes associated with mean birth-weight.
  - Fewer genes for very low, or high birth-weight would be passed to the next generation.

**Any one correct point - 1 mark**

(d) Directional

**Correct - 1 mark**

(e) (i) & (ii)

<b>UK</b>	<b>XS</b>
<b>3</b>	
<b>1</b>	
<b>1</b>	
	<b>2</b>

CAPE BIOLOGY

UNIT 2 - PAPER 032

MARK SCHEME

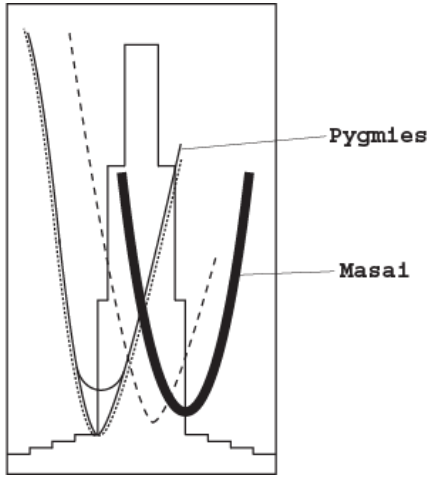

Labelled and correctly placed graphs - 1 mark each

--	--

Question 3. (continued)

(f)	(i)	No.	3 wks.	6 wks.	
		3	(2.8)	(2.7)	both correct - 1 mark
		9	(8.2)	(7.8)	both correct - 1 mark
		15	(11)	(8)	both correct - 1 mark

Correct figures are in brackets - allow very slight variations

(ii) 11 - 12 piglets per litter. These piglets have the maximum survival after 6 weeks.

Correct number with reason - 2 marks

UK	XS
	3

CAPE BIOLOGY

UNIT 2 - PAPER 032

MARK SCHEME

5	10

**Specific Objectives:**